

Stainless Steel Heat Exchanger EXCLUSIVE

Designed to prevent corrosion, warping and weld breakage. Built to last decades, not years.

Digital Hour Meter STANDARD

Tracks runtime

Accutemp Preheater PATENTED

Rapidly heats the widest range of viscosities of used oil, synthetic oils and other acceptable fuels.

Integrated Air Compressor STANDARD

Built in so you don't have to connect to and rely on shop air. Providing 24/7 heating availability.

Side Suction Metering Fuel Pump PATENTED

Reliable, consistent fuel delivery regardless of fuel type (up to 90W) with no manual adjustments.

Low Fuel Cut Off EXCLUSIVE*

Turns off the furnace before running out of fuel – preventing time-consuming troubleshooting, shutdowns and repriming.

*included with fuel delivery kits, complete systems and with furnace only.



Elevated Fuel Pick Up EXCLUSIVE

- 1) Pump can be mounted at the fuel source—instead of on top of the tank—so the pump is flooded with used oil, not air!
- 2) Fuel pick up is six inches above the bottom of the tank, above water and sludge, ensuring only used oil is sent to the furnace.
- 3) Easy spin-on stainless mesh filter.



Flame Retention Head PATENTED

This patented design creates a hotter flame than competitor brands for complete fuel combustion and highest heat output. Less ash is produced resulting in longer maintenance intervals than competitor brands.

Swing Away Burner and Ash Removal Port STANDARD

This convenient combination makes cleaning the chamber faster and easier than any other brand. One tool, 30 minutes or less.

Fuel Gauge STANDARD

Visual indicator of how much used oil is in your tank.

Drain Valve EXCLUSIVE

Makes it simple to purge water or other contaminants that naturally settle in the bottom of the tank.

Class A Flue Kit STANDARD*

Stainless steel interior, double-wall flue kits are UL-listed and meet local codes.

*standard for complete system or sold separately.

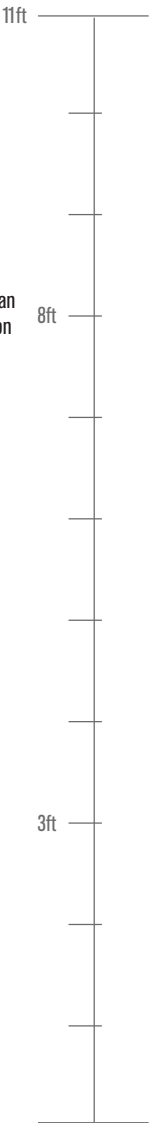

Pictured: 200H on 250 tank and Class A Flue Kit.

140H

Heats up to 3,500 square feet



200H

Heats up to 5,000 square feet



350H

Heats up to 9,000 square feet



Furnace Only

	ENGLISH	METRIC	ENGLISH	METRIC	ENGLISH	METRIC
Fuel Flow Rate	1.0 gallons/hour	3.78 liters/hour	1.4 gallons/hour	5.3 liters/hour	2.5 gallons/hour	9.4 liters/hour
BTU Input	140,000 BTU per hour	41.6 kW per hour	200,000 BTU per hour	58.3 kW per hour	350,000 BTU per hour	102 kW per hour
Heat Rise Over Input Air	100° - 120° F	37.8-48.9 C	100° - 120° F	37.8-48.9 C	100° - 120° F	37.8-48.9 C
Air Flow	1000 cfm	28cu. m/min	1500 cfm	42cu. m/min	2600 cfm	74 cu. m/min
Warm Air Outlet Dimensions	15"W x 15"H	38cm W x 38cm H	15"W x 15"H	38cm W x 38cm H	15"W x 15"H	38cm W x 38cm H
Exhaust Flue Diameter	6" or 8" diameter	15cm or 20cm diameter	6" or 8" diameter	15 cm or 20cm diameter	8" diameter	20cm diameter available
Furnace Dimensions	18"H x 18"W x 92"L	46cm H x 46cm W x 234cm L	18"H x 18"W x 103"L	46cm H x 46cm W x 262cm L	22"H x 22"W x 117"L	56cm H x 56cm W x 297cm L
Furnace Weight	295 lbs	132 kg	315 lbs	142 kg	415 lbs	188 kg

Complete Systems

140H Furnace +
Storage Tank, Draft Gauge and Class A Flue Kit

200H Furnace +
Storage Tank, Draft Gauge and Class A Flue Kit

350H Furnace +
Storage Tank, Draft Gauge and Class A Flue Kit

	ENGLISH	METRIC	ENGLISH	METRIC	ENGLISH	METRIC
130 Gal Storage Tank (single wall)	130 gallons	492.10 liters	130 gallons	492.10 liters	NA	NA
Tank Dimensions	32"H x 30"W x 38"L	81 cm H x 76cm W x 96cm L	32"H x 30"W x 38"L	81 cm H x 76cm W x 96cm L	NA	NA
Shipping Weight	698 lbs	317 kg	720 lbs	327 kg	NA	NA
200 Gal Storage Tank (single wall)	200 gallons	757 liters	200 gallons	757 liters	NA	NA
Tank Dimensions	32"H x 30"W x 48"L	81 cm H x 76cm W x 121cm L	32"H x 30"W x 48"L	81 cm H x 76cm W x 121cm L	NA	NA
Shipping Weight	750 lbs	340 kg	770 lbs	349 kg	NA	NA
250 Gal Storage Tank	250 gallons	946 liters	250 gallons	946 liters	250 gallons	946 liters
Tank Dimensions (single wall)	32"H x 30"W x 61"L	81cm H x 78cm W x 152 cm L	32"H x 30"W x 61"L	81cm H x 76cm W x 152 cmL	32"H x 30"W x 61"L	81cm H x 76cm W x 152 cmL
Tank Dimensions (double wall)	40"H x 31"W x 61"L	102 cm H x 79cm W x 155cm L	40"H x 31"W x 61"L	102 cm H x 79cm W x 155cm L	40"H x 31"W x 61"L	102 cm H x 79cm W x 155cm L
Shipping Weight (single wall)	749 lbs	340 kg	770 lbs	349 kg	899 lbs	408 kg
Shipping Weight (double wall)	976 lbs	442 kg	998 lbs	453 kg	1127 lbs	511 kg

Approved Fuels

Used crankcase oils, ATF, No. 2 fuel oil, up to 90 weight gear oil and diesel fuel

Electrical Req.

115 VAC 60Hz, 25 amps | maximum dedicated circuit

Warranty

10 years on heat exchanger, five years full and five years prorated
Up to 2 years on parts*

*One year warranty standard. Second year warranty requires product registration within 30 days of product receipt.

Regulation and Certification

EPA approved
UL-Listed - U.S. and Canada



2212 Camplain Road
Hillsborough, NJ 08844
1-888-8FC-LIFT



5901 Crossings Boulevard | Antioch, TN 37013
(800) 335-3092 | www.energylogic.com



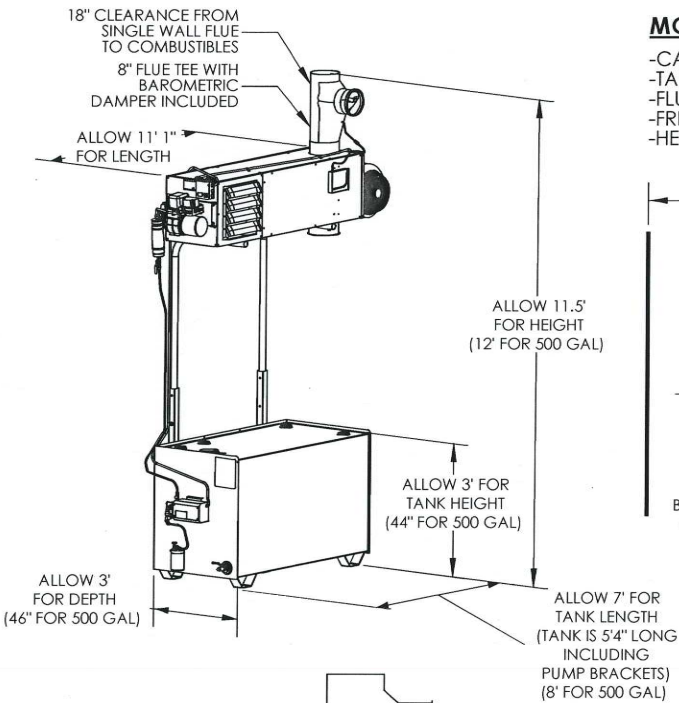

MODEL EL-140H (SHOWN WITH 250 GALLON SW TANK)

- CABINET WEIGHT WITH BURNER AND BLOWER: APPR 295 LBS
- TANK WEIGHT EMPTY: APPR 425 LBS (600 LBS FOR 500 Gallon SW)
- FLUE DIAMETER: 8"
- FREE AIR DELIVERY: 1000 CFM
- HEATING AREA: APPR 3500 SQ FT WITH 16' CEILINGS

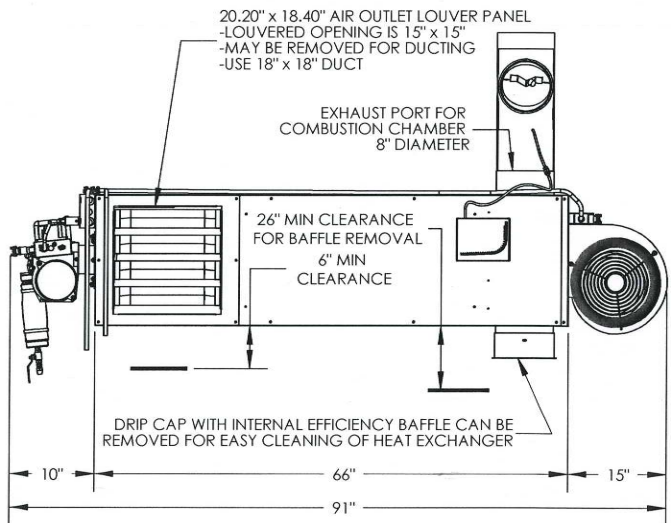
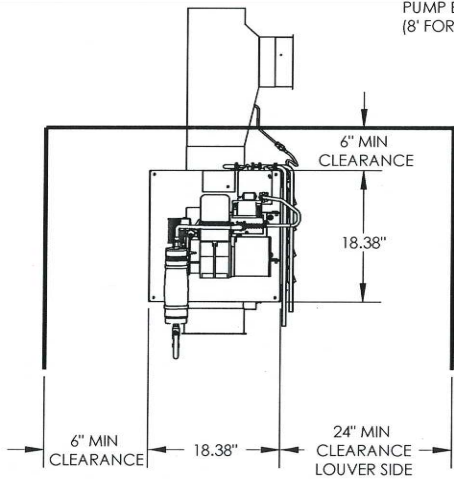
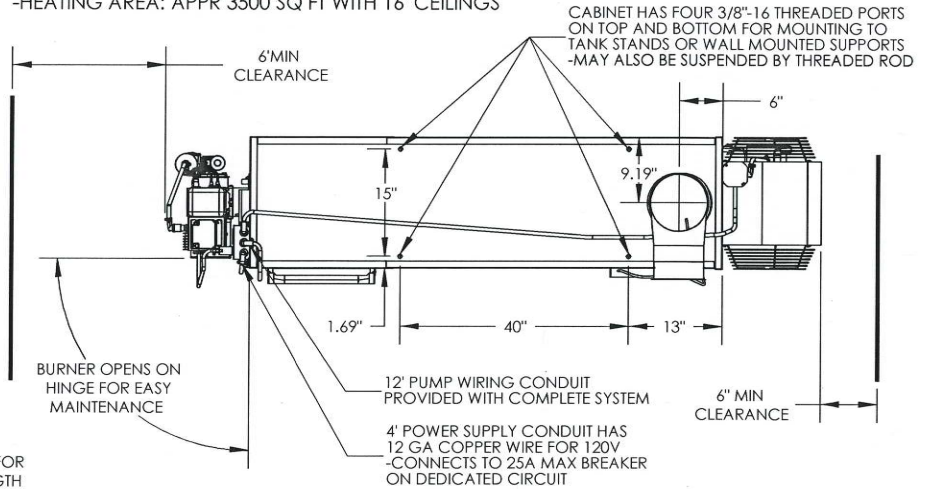

ITEM # 98030025