

Lock-Out Valves and Air Preparation

Catalog 3523-TRN | May 2020



ENGINEERING YOUR SUCCESS.

Parker is protecting your most valuable assets...



Standard 190.147

- This applies to the servicing and maintenance of a machine or equipment.
- Any new, replacement, repair, or renovation to a machine must include an energy isolation device that can accept a lock out device.
- Lock out devices should not be used for any other purposes
- Verification of energy isolation is required



Standard Z244

- This applies to all machines
- Lockout / tagout is the primary method of hazardous energy control
- Machines shall be designed, manufactured, supplied, and installed with energy isolating devices



B155.1

- B11.0 applies to a broad range of machines, B11.TR6 is specific to machine tools, and B155.1 is specific to packaging and converting machines
- Energy isolating device shall:
 - Be capable of being locked in the OFF position only
 - Be easy to operate
 - Have an exhaust port equal or greater than its supply port
 - Have a pressure indicator that is visible to an operator to verify line is relieved of pressure

...By offering the best in pneumatic safety for machine maintenance:



Parker Solutions

- Dedicated energy isolation device
- Full exhaust port
- Verification of line exhaust
- Only lockable in OFF position
- Easily identifiable

Applications

Lockout valves are installed in pneumatic drop legs, or individual pneumatic control lines (see Figure 1). In accordance with OSHA procedures, lockout valves are used during maintenance and service procedures of pneumatically (air) operated equipment. Prior to servicing, the red handle is pressed inward, blocking pressure and relieving all downstream air pressure. A padlock is installed through the locking hasp, preventing accidental actuation during the maintenance procedure. Following maintenance, the padlock is removed and the red handle is pulled outward, returning air pressure to the system.

Placement of Lockout Device

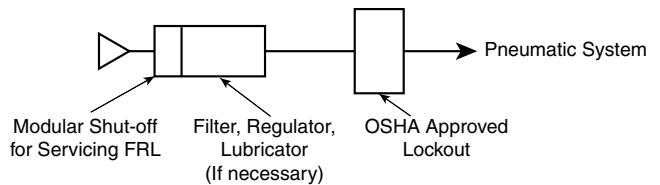

Operation

VALVE CLOSED

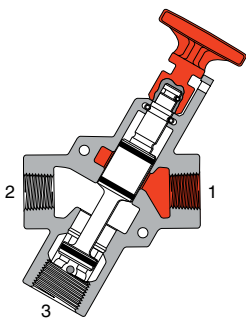

With a short inward push of the red handle, the flow of supply air is blocked from the outlet port. Downstream air flows from outlet to exhaust port. The valve must be padlocked while in this position during maintenance to prevent it from being inadvertently pulled outward and creating the potential for injury to people or machinery.

VALVE OPEN

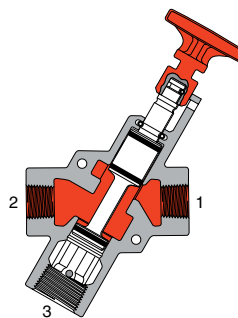

When the red handle is pulled out, supply air flows freely from inlet to outlet, and flow to the exhaust port is blocked. A detent keeps the handle in the open position. The handle is not designed to be locked in the open position so that the valve is always ready for shutoff.

- Parker has a complete offering from 1/2" to 2" ports
- Full exhaust reduces maintenance time = Increased uptime
- Teflon seals outperform competitor models using Buna-N
- Built-in pressure verification port sets Parker above the competition





Pneumatic Lockout Valves

Features:

- Used for compliance with OSHA 29 CFR part 1910
- 1/2" to 2" NPT pipe sizes
- Yellow cast aluminum body with red handle
- Inline or surface mountable
- Built in port for pressure verification to meet ANSI B11 and PMMI B155 requirements

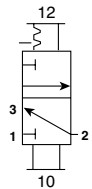

Material Specifications:

Description	FLV	Seals	Carboxylated Nitrile
Body	Cast Aluminum Alloy	Detent Spring	Stainless Steel
Handle	Plastic	Grease	Magnalube G*
Spool	Aluminum	* Trademark Magnalube	

Operating Information:

Inlet Operating Pressure	FLV
Standard	15 to 300 PSI
High Flow	15 to 300 PSI
Operating Temperature	+40°F to +175°F
Operating Media	clean, dry, compressed air (5 micron)

Flow Capacity:

Standard FLV Series	Port In/Out (in)	scfm In/Out	Port Exh (in)	scfm Exh
FLV4N6B	1/2	161.4	3/4	90.9
FLV6N6B	3/4	187.7	3/4	93.2
FLV6NAB	3/4	297.7	1 1/4	204
FLV8NAB	1	375	1 1/4	216

High Flow FLV Series	Port In/Out (in)	scfm In/Out	Port Exh (in)	scfm Exh
FLVBN6B	1 1/2	761.4	2	1156
FLVCN6B	2	918.2	2	1186



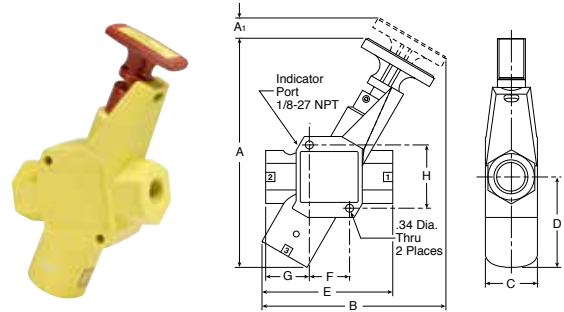

FLV Standard Pneumatic Lockout Valves

PART NO.	PORT IN/OUT (IN)	PORT EXH (IN)	A (IN)	A1 (IN)	B (IN)	C (IN)	D (IN)	E (IN)	F (IN)	G (IN)	H (IN)
FLV4N6B	1/2	3/4	8.32	.64	6.60	2.00	3.06	4.24	1.32	1.56	2.21
FLV6N6B	3/4	3/4	8.32	.64	6.60	2.00	3.06	4.24	1.32	1.56	2.21
FLV6NAB	3/4	1 1/4	9.91	.85	7.95	2.25	3.91	5.65	1.74	1.89	2.74
FLV8NAB	1	1 1/4	9.91	.85	7.95	2.25	3.91	5.65	1.74	1.89	2.74

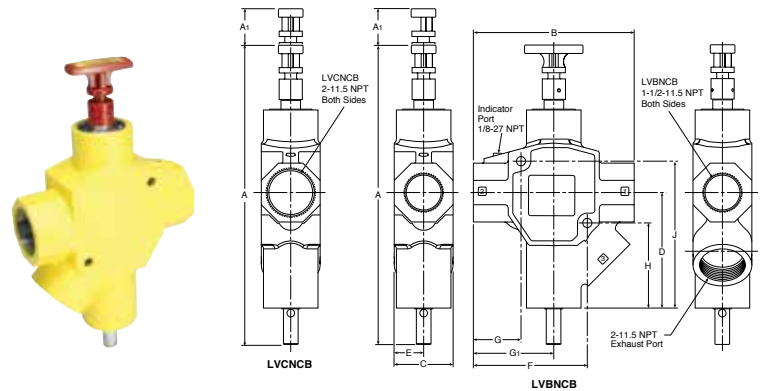

FLV High Flow Pneumatic Lockout Valves

PART NO.	PORT IN/OUT (IN)	PORT EXH (IN)	A (IN)	A1 (IN)	B (IN)	C (IN)	D (IN)	E (IN)	F (IN)	G (IN)	G1 (IN)	H (IN)	J (IN)
FLVBNCB	1 1/2	2	14.82	1.87	8.20	3.00	5.89	1.50	5.81	2.43	4.10	4.34	7.49
FLVCNCB	2	2	14.82	1.87	8.20	3.00	5.89	1.50	5.81	2.43	4.10	4.34	7.49



ES Silencers High Flow

PART NO.	PIPE SIZE	FLOW (SCFM)	HEX (IN)	LENGTH (IN)
FES75MC	3/4	893	1.62	4.56
FES125MC	1 1/4	1486	-	5.69
FES200MC	2	1580	2.99	7.68



Pressure Indicators Pop-Up

PART NO.	MATERIAL
F988A30	BRASS



Modular Particulate Filters

- Integral 1/2", 3/4" or 1 NPT ports
- High efficiency 5 micron element as standard
- Excellent water removal efficiency
- Robust but lightweight aluminum construction
- Positive bayonet latch to ensure correct & safe fitting

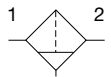

Manual drain

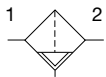

Auto drain

Material Specifications:

Body, Metal Bowl	Aluminum	Seals	Nitrile
Body Cap	ABS	Sight Gauge	Nylon (FP32 and FP33) Polypropylene (FP3Y)
Element Retainer/Baffle	Acetal	Drains: Manual Automatic	Acetal (FP3Y) PA / Ø 10mm brass connection (FP3Y)
Filter Element	Sintered Polyethylene		

Operating Information:

	FP32 (Compact)	FP33 (Standard)	FP3Y (High-Flow)
Supply pressure (max) Metal Bowl	250 PSIG (17 bar)	250 PSIG (17 bar)	254 PSIG (17.5 bar)
Operating Temperature Metal Bowl	-13°F to +150°F (-25°C to +65.5°C)	-13°F to +150°F (-25°C to +65.5°C)	+14°F to +140°F (-10°C to +60°C)
Standard Filtration	5 micron	5 micron	5 micron
Flow Capacity*	1/2 80 SCFM (18 dm ³ /s) 3/4 – 1 –	85 SCFM (40 dm ³ /s) 102 SCFM (48 dm ³ /s) –	252 SCFM (119 dm ³ /s) 252 SCFM (119 dm ³ /s) 252 SCFM (119 dm ³ /s)

*Inlet pressure 91.3 PSIG (6.3 bar), pressure drop 4.9 PSIG (0.34 bar).

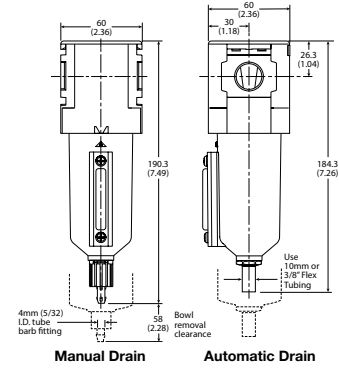

FP32 Compact Particulate Filter

PART NO.	PORT SIZE (IN)	METAL BOWL/DRAIN TYPE
FP32FB94ESMN	1/2	MANUAL
FP32FB94ESAN	1/2	AUTO

FP32FB 1/2" Filter

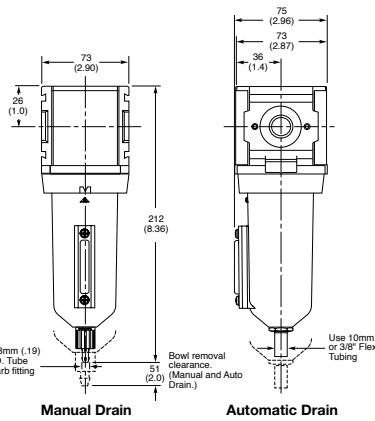
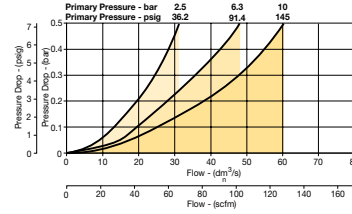

FP33 Standard Particulate Filter

PART NO.	PORT SIZE (IN)	METAL BOWL/DRAIN TYPE
FP33FA94ESMN	1/2	MANUAL
FP33FA94ESAN	1/2	AUTO
FP33FA96ESMN	3/4	MANUAL
FP33FA96ESAN	3/4	AUTO

FP33FA 1/2" Filter

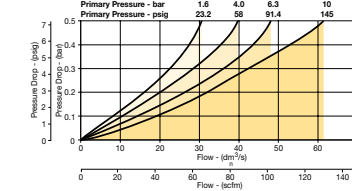

FP33FA 3/4" Filter

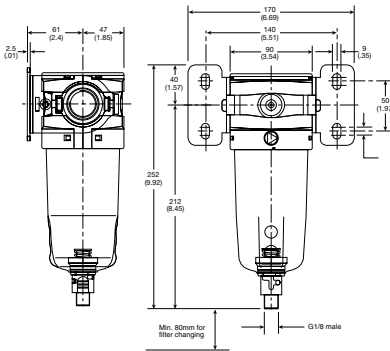
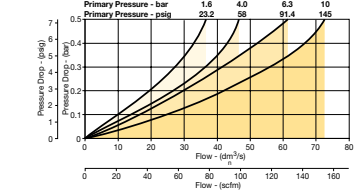

FP3Y High-Flow Particulate Filter

PART NO.	PORT SIZE (IN)	METAL BOWL/DRAIN TYPE
FP3YFA96ESCN	3/4	MANUAL
FP3YFA96ESAN	3/4	AUTO
FP3YFA98ESAN	1	MANUAL
FP3YFA98ESAN	1	AUTO

(3/4") Filter

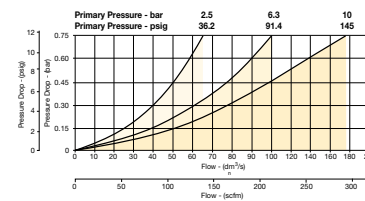

(1") Filter

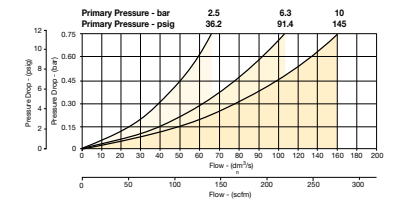



Modular Coalescing Filters

- Integral 1/2", 3/4" or 1 NPT ports
- Removes liquid aerosols and sub micron particles
- Oil free air for critical applications, such as air gauging, pneumatic instrumentation and control
- Positive bayonet latch to ensure correct & safe fitting

Note: To optimize the life of coalescing element, it is advisable to install a pre-filter with a 5 micron element upstream of the coalescing filter. To optimize the life of an Adsorber, if used, it is advisable to install a Coalescing Filter upstream of the Adsorber. Adsorber element should be replaced approximately every 1000 hours of service.

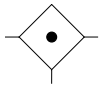

Material Specifications:

Body, Metal Bowl	Aluminum
Body Cap	ABS (FP33)
Filter Cover	ABS (FPY3)
Element Retainer/Baffle	Acetal
Filter Element	Sintered Polyethylene

Seals	Nitrile
Sight Gauge	Nylon (FP32 and FP33) Polypropylene (FP3Y)
Drains: Manual Automatic	Acetal (FP3Y) PA / Ø 10mm brass connection (FP3Y)

Operating Information:

	FP32 (Compact)	FP33 (Standard)	FP3Y (High-Flow)
Supply pressure (max) Metal Bowl	150 PSIG (10 bar)	150 PSIG (10 bar)	254 PSIG (17.5 bar)
Operating Temperature Metal Bowl	-13°F to +150°F (-25°C to +65.5°C)	-13°F to +150°F (-25°C to +65.5°C)	+14°F to +140°F (-10°C to +60°C)
Standard Filtration	0.01 micron	0.01 micron	0.01 micron
Energy Efficient Flow*	23 SCFM (11 dm ³ /s)	42 SCFM (20 dm ³ /s)	104 SCFM (49 dm ³ /s)
Maximum Flow**	38 SCFM (28 dm ³ /s)	72 SCFM (34 dm ³ /s)	120 SCFM (59 dm ³ /s)

*Inlet pressure 91.3 PSIG (6.3 bar), pressure drop 3 PSIG (0.2 bar) saturated element.

**Inlet pressure 91.3 PSIG (6.3 bar), pressure drop 6 PSIG (0.4 bar) saturated element.

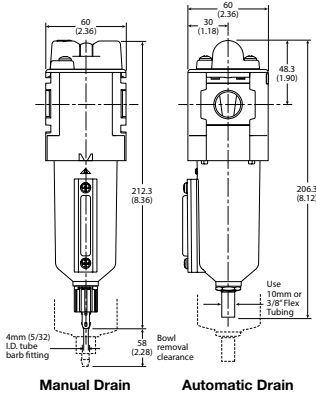

FP32 Compact Coalescing And Adsorber Filter

PART NO.	PORT SIZE (IN)	METAL BOWL/DRAIN TYPE
FP32FB94DSMN	1/2	MANUAL
FP32FB94DSAN	1/2	AUTO

P32FB - 0.01 micron flow

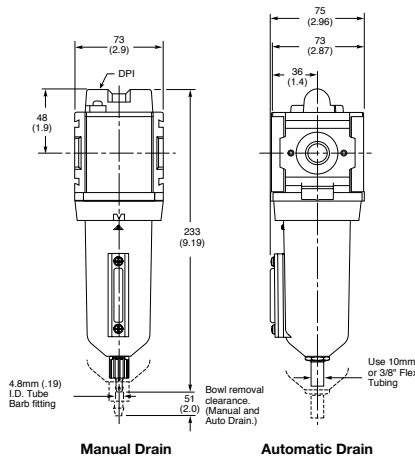
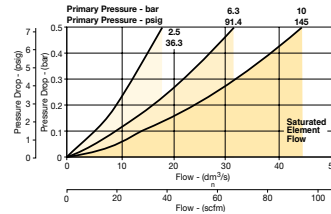

FP33 Standard Coalescing and Adsorber Filter

PART NO.	PORT SIZE (IN)	METAL BOWL/DRAIN TYPE
FP33FA94DSMN	1/2	MANUAL
FP33FA94DSAN	1/2	AUTO
FP33FA96DSMN	3/4	MANUAL
FP33FA96DSAN	3/4	AUTO

P33FA - 0.01 micron flow

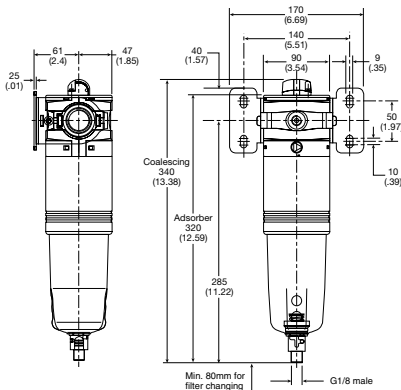
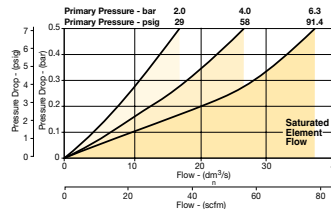

FP3Y High-Flow Coalescing Filter

PART NO.	PORT SIZE (IN)	METAL BOWL/DRAIN TYPE
FP3YFA96DSCN	3/4	MANUAL
FP3YFA96DSAN	3/4	AUTO
FP3YFA98DSCN	1	MANUAL
FP3YFA98DSAN	1	AUTO

(3/4") 0.01 Micron Coalescing Filter Saturated

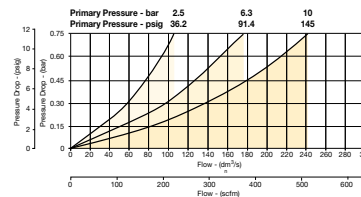

(1") 0.01 Micron Coalescing Filter Saturated

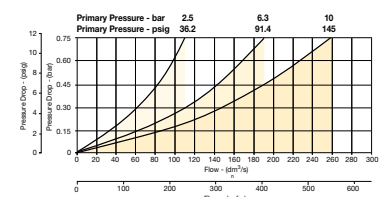

Modular Regulators



- Integral 1/2", 3/4" or 1 NPT ports
- Robust but lightweight aluminum construction
- Secondary pressure ranges 0-30 PSIG (0-2 bar), 0-60 PSIG (0-4 bar), 0-125 PSIG (0-8 bar), 0-250 PSIG (0-17 bar)
- Secondary aspiration plus balanced poppet provides quick response and accurate pressure regulation
- Relieving
- Non-rising knob

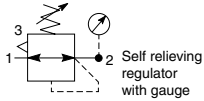

Material Specifications:

Body	Aluminum
Adjustment Knob	Acetal (FP32 and FP33) Glass-filled Polyamide (FP3Y)
Body Cap	ABS
Bonnet	33% Glass-filled Nylon (FP32 and FP33) Glass-filled Polyamide (FP3Y)
Diaphragm Assembly	Nitrile / Zinc (FP32 and FP33)
Bottom Plug	33% Glass-filled Nylon (FP32)

Operating Information:

	FP32 (Compact)	FP33 (Standard)	FP3Y (High-Flow)
Supply pressure (max)	300 PSIG (20 bar)	300 PSIG (20 bar)	254 PSIG (17.5 bar)
Operating Temperature	-13°F to +150°F (-25°C to +65.5°C)	-13°F to +150°F (-25°C to +65.5°C)	-40°F to +140°F (-40°C to +60°C)**
Flow Capacity*	1/2 165 SCFM (78 dm ³ /s) 3/4 – 1 –	233 SCFM (110 dm ³ /s) 233 SCFM (110 dm ³ /s) –	– – 680 SCFM (321 dm ³ /s)

*Inlet pressure 145 PSIG (10 bar), pressure drop 91.3 PSIG (6.3 bar) saturated element.

**Air supply must be dry enough to avoid ice formation at temperatures below 35.6°F (2°C).

⚠ WARNING

Product rupture can cause serious injury.
Do not connect regulator to bottled gas.
Do not exceed maximum primary pressure rating.

CAUTION:

REGULATOR PRESSURE ADJUSTMENT –

The working range of knob adjustment is designed to permit outlet pressures within their full range. Pressure adjustment beyond this range is also possible because the knob is not a limiting device. This is a common characteristic of most industrial regulators, and limiting devices may be obtained only by special design.

For best performance, regulated pressure should always be set by increasing the pressure up to the desired setting.

Valve Assembly	Brass / Nitrile (FP32) Brass / Nitrile / Acetal (FP33) Brass / NBR (FP3Y)
Springs	Steel S.S. (FP32 and FP33)
Seals	Nitrile / Zinc (FP32 and FP33) Nitrile / NBR (FP3Y)
Screws	Nitrile / NBR (FP3Y)
Panel Nut	Acetal (FP32 and FP33)

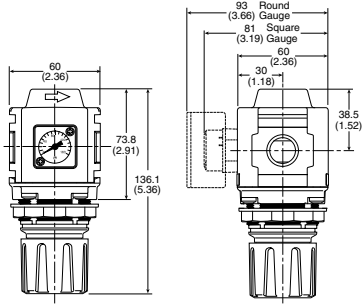

FP32 Compact Regulator

PART NO.	PORT SIZE (IN)	RELIVING PRESSURE (PSI)	RELIVING PRESSURE (BAR)	GAUGE
FP32RB94BNGP	1/2	125	8	ROUND

NOTE: 48 mm (1.90 in.) hole required for panel nut mounting.

P32RB 1/2" Regulator

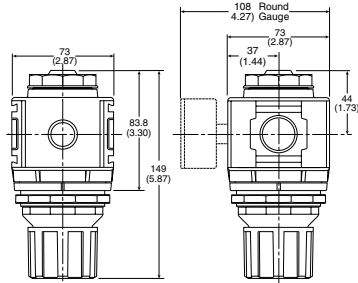
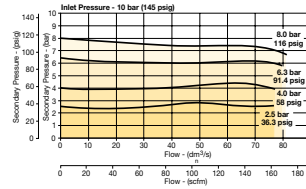

FP33 Standard Regulator

PART NO.	PORT SIZE (IN)	RELIVING PRESSURE (PSI)	RELIVING PRESSURE (BAR)	GAUGE
FP33RA94BNGP	1/2	125	8	ROUND
FP33RA96BNGP	3/4	125	8	ROUND

NOTE: 61 mm (2.40 in.) hole required for panel nut mounting.

P33RA 1/2" Regulator

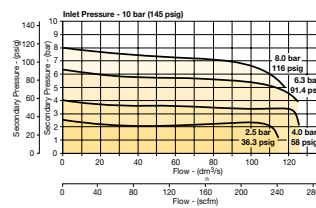

P33RA 3/4" Regulator

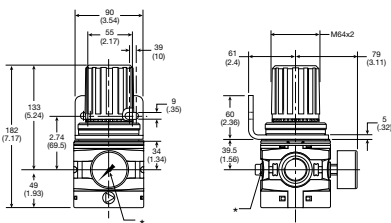
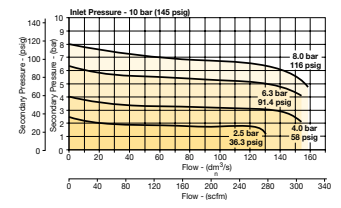

FP3Y High-Flow Regulator

PART NO.	PORT SIZE (IN)	RELIVING PRESSURE (PSI)	RELIVING PRESSURE (BAR)	GAUGE
FP3YRA96BNFN	3/4	145	10	ROUND
FP3YRA98BNFN	1	145	10	ROUND

(3/4") Regulator

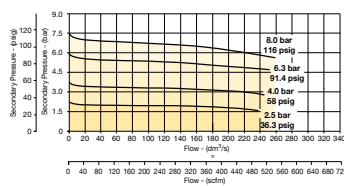

(1") Regulator

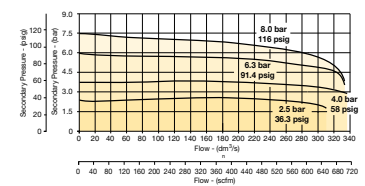



Modular Filters / Regulators

- Integral 1/2", 3/4" or 1 NPT ports
- High efficiency 5 micron element as standard
- Excellent water removal efficiency
- Robust but lightweight aluminum construction
- Positive bayonet latch to ensure correct & safe fitting
- Secondary pressure ranges 0-30 PSIG (0-2 bar), 0-60 PSIG (0-4 bar), 0-125 PSIG (0-8 bar), 0-250 PSIG (0-17 bar)
- Secondary aspiration plus balanced poppet provides quick response and accurate pressure regulation

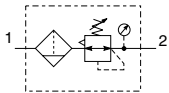

⚠ WARNING

Product rupture can cause serious injury.
Do not connect regulator to bottled gas.
Do not exceed maximum primary pressure rating.

CAUTION:

REGULATOR PRESSURE ADJUSTMENT –

The working range of knob adjustment is designed to permit outlet pressures within their full range. Pressure adjustment beyond this range is also possible because the knob is not a limiting device. This is a common characteristic of most industrial regulators, and limiting devices may be obtained only by special design.

For best performance, regulated pressure should always be set by increasing the pressure up to the desired setting.

Material Specifications:

Seals	Nitrile
Springs	Steel
Valve Assembly	Brass / Nitrile (FP32 and FP33) Brass / NBR (FP3Y)

Diaphragm Assembly	Nitrile / Zinc (FP32 and FP33)
Panel Nut	Acetal
Sight Gauge	Nylon (FP32 and FP33), Polypropylene (FP3Y)

Operating Information:

	FP32 (Compact)	FP33 (Standard)	FP3Y (High-Flow)
Supply pressure (max)			
Metal Bowl	250 PSIG (17 bar)	250 PSIG (17 bar)	254 PSIG (17.5 bar)
Operating Temperature			
Metal Bowl	-13°F to +150°F (-25°C to +65.5°C)	-14°F to +150°F (-25°C to +65.5°C)	-40°F to +140°F (-40°C to +60°C)**
Standard Filtration	5 micron	5 micron	5 micron
Flow Capacity*			
1/2	136 SCFM (64 dm ³ /s)	210 SCFM (99 dm ³ /s)	–
3/4	–	230 SCFM (108 dm ³ /s)	–
1	–	–	502 SCFM (237 dm ³ /s)

*Inlet pressure 145 PSIG (10 bar). Secondary pressure drop 91.3 PSIG (6.3 bar).
**Air supply must be dry enough to avoid ice formation at temperatures below 35.6°F (2°C).

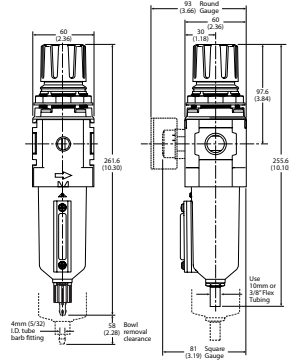

FP32 Compact Filter / Regulator

PART NO.	PORT SIZE (IN)	RELIVING PRESSURE		FILTER TYPE	FILTRATION RATING	METAL BOWL/ DRAIN TYPE
		PSI	BAR			
FP32EB94ESMBNGP	1/2	125	8	PARTICULATE	5 MICRON	MANUAL
FP32EB94ESABNGP	1/2	125	8	PARTICULATE	5 MICRON	AUTO

P32EB 1/2" Filter/Regulator

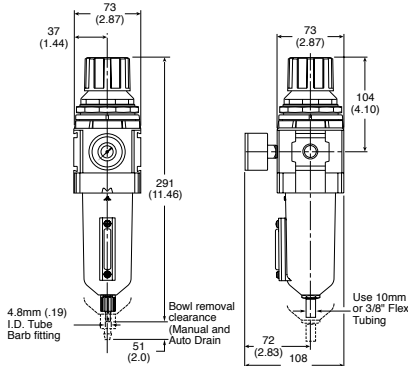
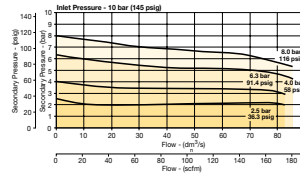

FP33 Standard Filter / Regulator

PART NO.	PORT SIZE (IN)	RELIVING PRESSURE		FILTER TYPE	FILTRATION RATING	METAL BOWL/ DRAIN TYPE
		PSI	BAR			
FP33EA94ESMBNGP	1/2	125	8	PARTICULATE	5 MICRON	MANUAL
FP33EA94ESABNGP	1/2	125	8	PARTICULATE	5 MICRON	AUTO
FP33EA96ESMBNGP	3/4	125	8	PARTICULATE	5 MICRON	MANUAL
FP33EA96ESABNGP	3/4	125	8	PARTICULATE	5 MICRON	AUTO

P33EA 1/2" Filter / Regulator

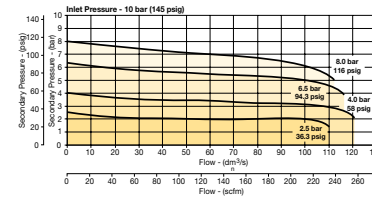

P33EA 3/4" Filter/Regulator

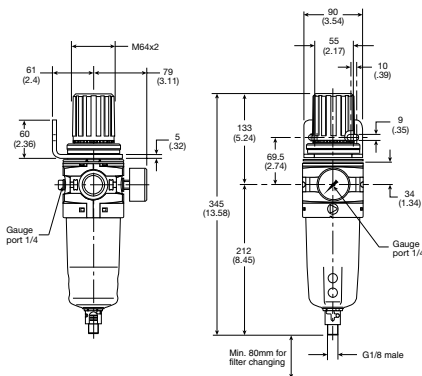
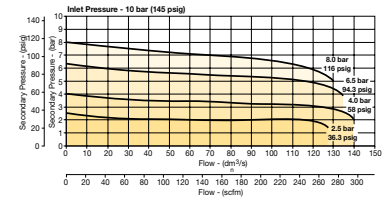

FP3Y High-Flow Filter / Regulator

PART NO.	PORT SIZE (IN)	RELIVING PRESSURE		FILTER TYPE	FILTRATION RATING	METAL BOWL/ DRAIN TYPE
		PSI	BAR			
FP3YEA96ESCBNFN	3/4	125	8	PARTICULATE	5 MICRON	MANUAL / SEMI AUTO
FP3YEA96ESABNFN	3/4	125	8	PARTICULATE	5 MICRON	AUTO
FP3YEA98ESCBNFN	1	125	8	PARTICULATE	5 MICRON	MANUAL / SEMI AUTO
FP3YEA98ESABNFN	1	125	8	PARTICULATE	5 MICRON	AUTO

(3/4") 5 Micron Filter / Regulator

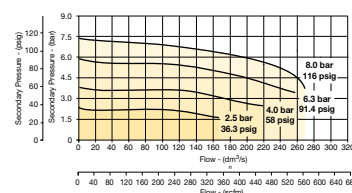

(1") 5 Micron Filter / Regulator

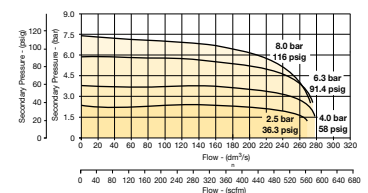

Modular Lubricators



- Integral 1/2", 3/4" or 1 NPT ports
- Robust but lightweight aluminum construction
- Proportional oil delivery over a wide range of air flows
- Finger tip ratchet control for precise oil drip rate adjustment

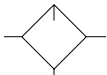

Lubricator
with drain

Material Specifications:

Body, Metal Bowl	Aluminum	Suggested Lubricant	ISO/ASTM VG 32 (FP32 and FP33)
Body Cap	ABS	Pick-up Filter	Sintered Bronze (FP32 and FP33)
Seals	Nitrile	Top & Bottom End Cap	Glass-filled Nylon (FP3Y)
Sight Dome	Nylon (FP32 and FP33) Polyamide (FP3Y)	Bayonet Support	Nylon (FP3Y)
Sight Gauge	Polycarbonate (FP32 and FP33) Polypropylene (FP3Y)		

Operating Information:

	FP32 (Compact)	FP33 (Standard)	FP3Y (High-Flow)
Supply pressure (max) Metal Bowl	250 PSIG (17 bar)	250 PSIG (17 bar)	254 PSIG (17.5 bar)
Operating Temperature Metal Bowl	+14°F to +150°F (-10°C to +65.5°C)	+14°F to +150°F (-10°C to +65.5°C)	+14°F to +140°F (-10°C to +60°C)**
Flow Capacity*			
1/2	90 SCFM (42 dm ³ /s)	110 SCFM (52 dm ³ /s)	—
3/4	—	150 SCFM (71 dm ³ /s)	343 SCFM (162 dm ³ /s)
1	—	—	390 SCFM (184 dm ³ /s)

*Inlet pressure 91.3 PSIG (6.3 bar), pressure drop 4.9 PSIG (0.34 bar).

**Air supply must be dry enough to avoid ice formation at temperatures below 35.6°F (2°C).

Low flow start point (lubrication pick-up): at 91.4 PSIG (6.3 bar) inlet pressure 1.1 SCFM (0.5 dm³/s).

Typical flow with 91.4 PSIG (6.3 bar) inlet pressure and 10.2 PSIG (0.7 bar) pressure drop: 390 SCFM (184 dm³/s).

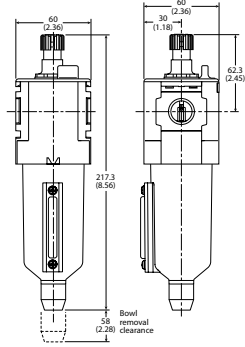

FP32 Compact Lubricator

PART NO.	PORT SIZE (IN)	BOWL TYPE	TYPE
FP32LB94LSNN	1/2	METAL /NO DRAIN	MIST / SIGHT GAUGE

P32LB 1/2" Lubricator

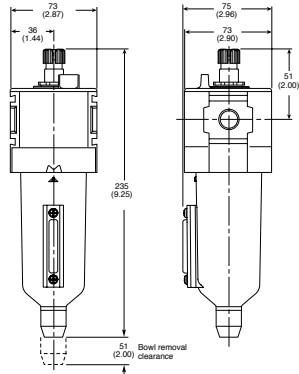
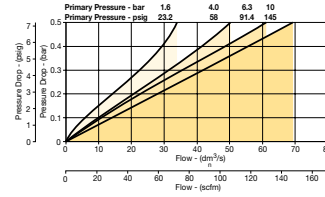

FP33 Standard Lubricator

PART NO.	PORT SIZE (IN)	BOWL TYPE	TYPE
FP33LA94LSNN	1/2	METAL /NO DRAIN	MIST / SIGHT GAUGE
FP33LA96LSNN	3/4	METAL /NO DRAIN	MIST / SIGHT GAUGE

P33LA 1/2" Lubricator

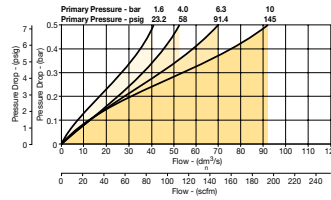

P33LA 3/4" Lubricator

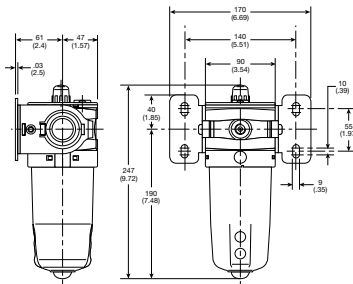
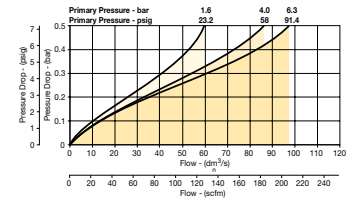

FP3Y High-Flow Lubricator

PART NO.	PORT SIZE (IN)	BOWL TYPE	TYPE
FP3YLA96LSNN	3/4	METAL /NO DRAIN	MIST
FP3YLA98LSNN	1	METAL /NO DRAIN	MIST

(3/4") Lubricator

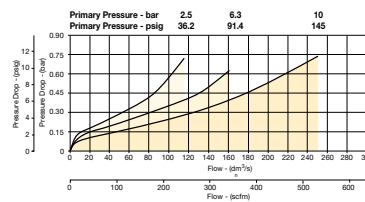

(1") Lubricator

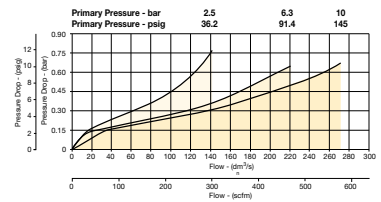



Modular Combinations

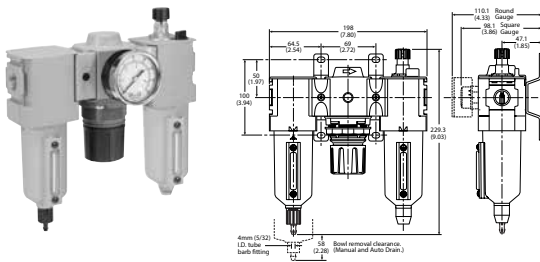

FP32 Compact Filter + Regulator + Lubricator

PART NO.	PORT SIZE (IN)	FILTER TYPE	FILTRATION RATING	DRAIN TYPE	FLOW	
					SCFM	DM ³ /S
FP32CB94SEMGNLW	1/2	PARTICULATE	5 MICRON	MANUAL	85	40
FP32CB94SEANGLNW	1/2	PARTICULATE	5 MICRON	AUTO	85	40

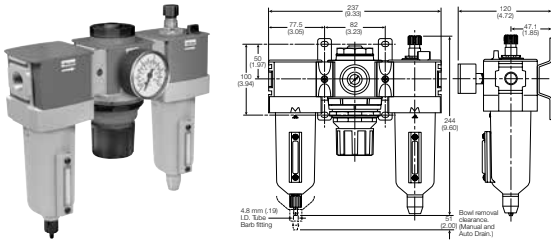

FP33 Standard Filter + Regulator + Lubricator

PART NO.	PORT SIZE (IN)	FILTER TYPE	FILTRATION RATING	DRAIN TYPE	FLOW	
					SCFM	DM ³ /S
FP33CB94SEMGNLW	1/2	PARTICULATE	5 MICRON	MANUAL	90	43
FP33CB94SEANGLNW	1/2	PARTICULATE	5 MICRON	AUTO	90	43
FP33CB96SEMGNLW	3/4	PARTICULATE	5 MICRON	MANUAL	110	52
FP33CB96SEANGLNW	3/4	PARTICULATE	5 MICRON	AUTO	110	52

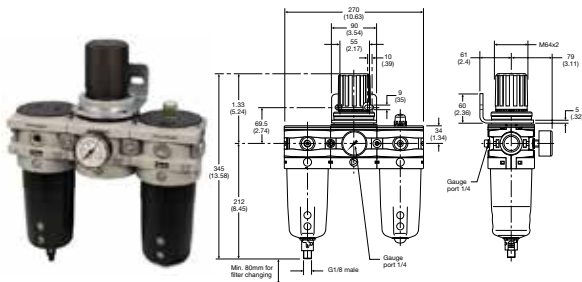

FP3Y High-Flow Filter + Regulator + Lubricator

PART NO.	PORT SIZE (IN)	FILTER TYPE	FILTRATION RATING	DRAIN TYPE	FLOW	
					SCFM	DM ³ /S
FP3YCB96SECNLFNF	3/4	PARTICULATE	5 MICRON	MANUAL / SEMI-AUTO	193	91
FP3YCB96SEANLFNF	3/4	PARTICULATE	5 MICRON	AUTO	193	91
FP3YCB98SECNLFNF	1	PARTICULATE	5 MICRON	MANUAL / SEMI-AUTO	369	174
FP3YCB98SEANLFNF	1	PARTICULATE	5 MICRON	AUTO	369	174

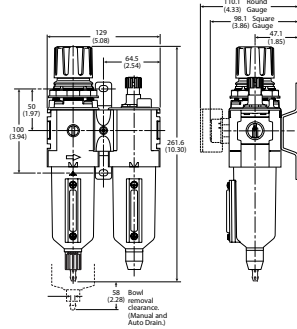

FP32 Compact Filter / Regulator + Lubricator

PART NO.	PORT SIZE (IN)	FILTER TYPE	FILTRATION RATING	DRAIN TYPE	FLOW	
					SCFM	DM3/S
FP32CA94SEMGNLW	1/2	PARTICULATE	5 MICRON	MANUAL	90	43
FP32CA94SEANGLW	1/2	PARTICULATE	5 MICRON	AUTO	90	43

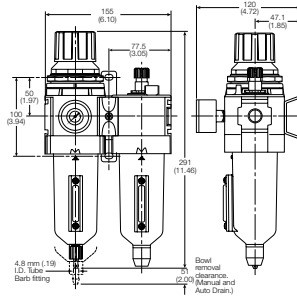

FP33 Standard Filter / Regulator + Lubricator

PART NO.	PORT SIZE (IN)	FILTER TYPE	FILTRATION RATING	DRAIN TYPE	FLOW	
					SCFM	DM3/S
FP33CA94SEMGNLW	1/2	PARTICULATE	5 MICRON	MANUAL	110	52
FP33CA94SEANGLW	1/2	PARTICULATE	5 MICRON	AUTO	110	52
FP33CA96SEMGNLW	3/4	PARTICULATE	5 MICRON	MANUAL	150	71
FP33CA96SEANGLW	3/4	PARTICULATE	5 MICRON	AUTO	150	71

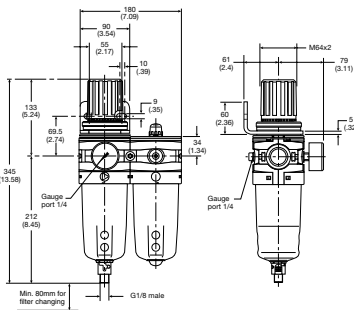

FP3Y High-Flow Filter / Regulator + Lubricator

PART NO.	PORT SIZE (IN)	FILTER TYPE	FILTRATION RATING	DRAIN TYPE	FLOW	
					SCFM	DM3/S
FP3YCA96SECNFLNF	3/4	PARTICULATE	5 MICRON	MANUAL / SEMI-AUTO	214	101
FP3YCA96SEANFLNF	3/4	PARTICULATE	5 MICRON	AUTO	214	101
FP3YCA98SECNFLNF	1	PARTICULATE	5 MICRON	MANUAL / SEMI-AUTO	356	168
FP3YCA98SEANFLNF	1	PARTICULATE	5 MICRON	AUTO	356	168

Modular Accessories / Kits



Modular Ball Valve

PART NO.	IN / OUT PORT SIZE (IN)	MODEL TYPE	EXHAUST PORT (IN)	THREAD TYPE	FLOW	
					SCFM	DM3/S
FP32VB94LBNN	1/2	FP32	1/4	NPT	258.5	122
FP33VB94LBNN	1/2	FP33	1/2	NPT	561.5	265
FP33VB96LBNN	3/4	FP33	1/2	NPT	678	320
FP3YVA96LBN	3/4	FP3Y	1/4	NPT	705.6	333
FP3YVA98LBN	1	FP3Y	1/4	NPT	705.6	333



Manifold Block

PART NO.	IN / OUT PORT SIZE (IN)	MODEL TYPE	AUXILIARY PORT SIZE TOP (IN)	AUXILIARY PORT SIZE BOTTOM (IN)	THREAD TYPE	FRONT AND BACK
FP32MA94024N	1/2	FP32	1/4	1/2	NPT	-
FP33MA96024N	3/4	FP33	1/4	1/2	NPT	-
FP3YMA9V0N	1	FP3Y	1/8	1	NPT	1/4



Panel Mount Plastic

PART NO.	SERIES
FP32KA00MP	FP32
FP33KA00MP	FP33



Panel Mount Nut Aluminum

PART NO.	SERIES
FP32KA00MM	FP32
FP33KA00MM	FP33
FP3YKA00MM	FP3Y



Neck Mounting Bracket Kit

PART NO.	SERIES
FP3YKA00MS	FP3Y



Lubricator Oil (P)

PART NO.	SIZE
FF442001	1 QRT
FF442002	1 GAL



Wall Mounting Brackets (P)

PART NO.	SERIES
FP3YKA00CW	FP3Y



Angle Bracket / L-Bracket

PART NO.	MODEL TYPE	DESCRIPTION
FP32KB00MR	FP32	ANGLE BRACKET (Fits to Regulator and Filter / Regulator Body)
FP32KA00ML	FP32	L-BRACKET (Fits to Filter and Lubricator Body)
FP33KA00MR	FP33	ANGLE BRACKET (Fits to Regulator and Filter / Regulator Body)
FP33KA00ML	FP33	L-BRACKET (Fits to Filter and Lubricator Body)



Body Connecting Kit

PART NO.	SERIES	DESCRIPTION
FP32KA00MT	FP32/FP33	T-BRACKET WITH BODY CONNECTOR
FP32KA00CB	FP32	BODY CONNECTOR
FP3YKA00CB	FP3Y	BODY CONNECTOR



Port Block Kit

PART NO.	MODEL TYPE	PORT SIZE (IN)	THREAD TYPE
P32KA94CP	FP32/FP33	1/2	NPT
P32KA96CP	FP32/FP33	3/4	NPT
P32KA14CP	FP32/FP33	1/2	BSPP
P32KA16CP	FP32/FP33	3/4	BSPP
P3YKA9BCP	FP3Y	1 1/2	NPT



Element Kit

PART NO.	SERIES	MICRONS
FP32KA00ESE	FP32	5
FP33KA00ESE	FP33	5
FP3YKA00ESE	FP3Y	5
FP32KA00ESC	FP32	0.01
FP33KA00ESC	FP33	0.01
FP3YKA00ESC	FP3Y	0.01



Regulator & Filter / Regulator Tamperproof Kit

PART NO.
FP32KB00AL



Tamperproof Knob Kit

PART NO.
FP32KB00AT



Threaded Connectors

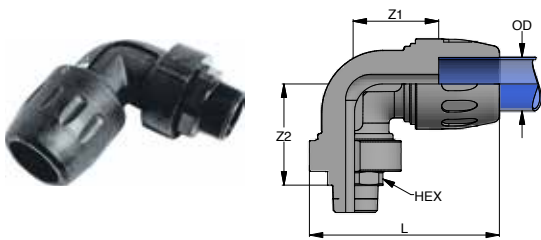

Male Threaded NPT 90° Elbow

PART NO.	OD (IN)	OD (MM)	THD SIZE (IN)	HEX (MM)	L (IN)	Z1 (IN)	Z2 (IN)	Z2 (MM)
6609 17 22	1/2	16,5	1/2	23	2.95	1.22	2.50	1.83
6609 25 22	1	25	1/2	27	3.63	1.59	2.97	2.09
6609 25 28	1	25	3/4	27	3.63	1.59	2.97	2.09
6609 25 35	1	25	1	36	3.63	2.44	3.05	2.17
6609 40 35	1 1/2	40	1	41	5.40	2.44	4.13	2.95
6609 40 43	1 1/2	40	1 1/4	50	5.40	2.44	4.33	3.15
6609 40 50	1 1/2	40	1 1/2	50	5.40	2.44	4.33	3.15
6609 40 44	1 1/2	40	2	60	5.40	2.44	4.76	3.35
6609 50 50	2	50	1 1/2	50	6.14	2.20	5.39	3.82
6609 50 44	2	50	2	60	6.14	2.20	5.47	3.90

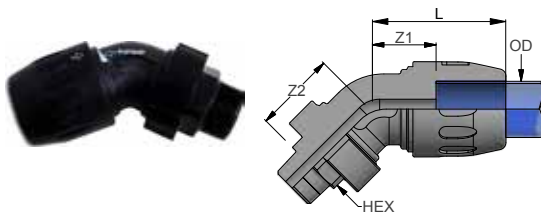

Male Threaded NPT 45° Elbow

PART NO.	OD (IN)	OD (MM)	THD SIZE (IN)	HEX (MM)	L (IN)	Z1 (IN)	Z2 (IN)
6619 25 22	1	25	1/2	27	2.42	1.28	1.65
6619 25 28	1	25	3/4	27	2.42	1.28	1.65
6619 25 35	1	25	1	36	2.42	1.28	1.73
6619 40 35	1 1/2	40	1	41	3.70	1.77	2.30
6619 40 43	1 1/2	40	1 1/4	50	3.70	1.77	2.52
6619 40 50	1 1/2	40	1 1/2	50	3.70	1.77	2.52
6619 40 44	1 1/2	40	2	60	3.70	1.77	2.52
6619 50 50	2	50	1 1/2	50	3.86	1.50	3.15
6619 50 44	2	50	2	60	3.86	1.50	3.23
6619 63 44	2 1/2	63	2	70	3.94	1.50	3.19

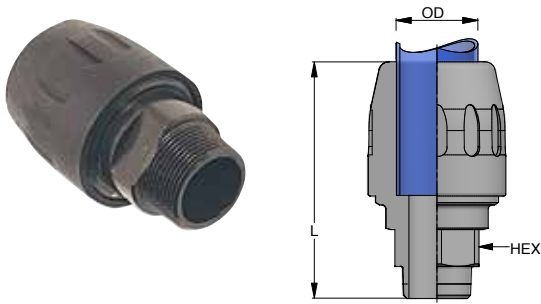

Male Threaded NPT Connector

PART NO.	OD (IN)	OD (MM)	THD SIZE (IN)	HEX (MM)	L (IN)
6605 17 22	1/2	16,5	1/2	24	2.64
6605 25 22	1	25	1/2	30	2.81
6605 25 28	1	25	3/4	30	2.81
6605 25 35	1	25	1	38	2.95
6605 40 35	1 1/2	40	1	41	4.53
6605 40 43	1 1/2	40	1 1/4	41	4.51
6605 40 50	1 1/2	40	1 1/2	50	4.63
6605 40 44	1 1/2	40	2	70	4.73



Male Threaded NPT Stud Adapter

PART NO.	OD (IN)	OD (MM)	THD SIZE (IN)	HEX (MM)	L (IN)	Z (IN)
6615 25 22	1	25	1/2	27	3.60	1.81
6615 25 28	1	25	3/4	27	3.60	1.81
6615 25 35	1	25	1	34	3.76	1.81
6615 40 43	1 1/2	40	1 1/4	50	4.76	1.81
6615 40 50	1 1/2	40	1 1/2	50	4.76	1.81
6615 50 50	2	50	1 1/2	50	4.96	3.54
6615 50 44	2	50	2	60	4.96	3.54



Male Threaded NPT Stud Nut

PART NO.	OD (IN)	OD (MM)	THD SIZE (IN)	HEX 1 (MM)	HEX 1 (MM)	L (IN)
6611 17 22	1/2	16,5	1/2	32	23	1.65
6611 25 22	1	25	1/2	46	27	1.71
6611 25 28	1	25	3/4	46	27	1.72
6611 25 35	1	25	1	46	36	1.93
6611 40 35	1 1/2	40	1	65	41	2.11
6611 40 43	1 1/2	40	1 1/4	65	50	2.34
6611 40 50	1 1/2	40	1 1/2	65	50	2.36
6611 40 44	1 1/2	40	2	65	60	2.56
6611 50 44	2	50	2	-	60	3.19
6611 50 50	2	50	1 1/2	-	60	3.07
6611 63 44	2 1/2	63	2	-	70	3.05

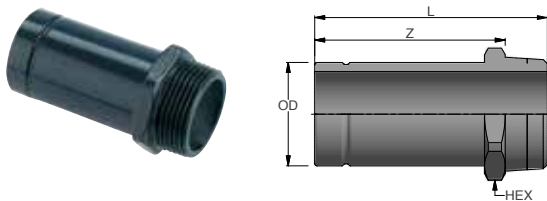

Male Threaded NPT Adapter

PART NO.	OD (IN)	OD (MM)	THD SIZE (IN)	HEX (MM)	L (IN)	Z (IN)
6621 17 22	1/2	16,5	1/2	24	2.26	1.66
6621 25 22	1	25	1/2	28	2.53	1.93
6621 25 28	1	25	3/4	28	2.57	1.93
6621 25 35	1	25	1	36	2.80	2.05
6621 40 43	1 1/2	40	1 1/4	46	3.75	2.90
6621 40 50	1 1/2	40	1 1/2	50	3.84	2.98

Safety Guide For Selecting And Using Pneumatic Division Products And Related Accessories

WARNING: FAILURE OR IMPROPER SELECTION OR IMPROPER USE OF PNEUMATIC DIVISION PRODUCTS, ASSEMBLIES OR RELATED ITEMS ("PRODUCTS") CAN CAUSE DEATH, PERSONAL INJURY, AND PROPERTY DAMAGE. POSSIBLE CONSEQUENCES OF FAILURE OR IMPROPER SELECTION OR IMPROPER USE OF THESE PRODUCTS INCLUDE BUT ARE NOT LIMITED TO:

- Unintended or mistimed cycling or motion of machine members or failure to cycle
- Work pieces or component parts being thrown off at high speeds.
- Failure of a device to function properly for example, failure to clamp or unclamp an associated item or device.
- Explosion
- Suddenly moving or falling objects.
- Release of toxic or otherwise injurious liquids or gasses.

Before selecting or using any of these Products, it is important that you read and follow the instructions below.

1. GENERAL INSTRUCTIONS

- 1.1. **Scope:** This safety guide is designed to cover general guidelines on the installation, use, and maintenance of Pneumatic Division Valves, FRLs (Filters, Pressure Regulators, and Lubricators), Vacuum products and related accessory components.
- 1.2. **Fail-Safe:** Valves, FRLs, Vacuum products and their related components can and do fail without warning for many reasons. Design all systems and equipment in a fail-safe mode, so that failure of associated valves, FRLs or Vacuum products will not endanger persons or property.
- 1.3. **Relevant International Standards:** For a good guide to the application of a broad spectrum of pneumatic fluid power devices see: ISO 4414:1998, Pneumatic Fluid Power – General Rules Relating to Systems. See www.iso.org for ordering information.
- 1.4. **Distribution:** Provide a copy of this safety guide to each person that is responsible for selection, installation, or use of Valves, FRLs or Vacuum products. Do not select, or use Parker valves, FRLs or vacuum products without thoroughly reading and understanding this safety guide as well as the specific Parker publications for the products considered or selected.
- 1.5. **User Responsibility:** Due to the wide variety of operating conditions and applications for valves, FRLs, and vacuum products Parker and its distributors do not represent or warrant that any particular valve, FRL or vacuum product is suitable for any specific end use system. This safety guide does not analyze all technical parameters that must be considered in selecting a product. The user, through its own analysis and testing, is solely responsible for:
 - Making the final selection of the appropriate valve, FRL, Vacuum component, or accessory.
 - Assuring that all user's performance, endurance, maintenance, safety, and warning requirements are met and that the application presents no health or safety hazards.
 - Complying with all existing warning labels and / or providing all appropriate health and safety warnings on the equipment on which the valves, FRLs or Vacuum products are used; and,
 - Assuring compliance with all applicable government and industry standards.
- 1.6. **Safety Devices:** Safety devices should not be removed, or defeated.
- 1.7. **Warning Labels:** Warning labels should not be removed, painted over or otherwise obscured.
- 1.8. **Additional Questions:** Call the appropriate Parker technical service department if you have any questions or require any additional information. See the Parker publication for the product being considered or used, or call 1-800-CPARKER, or go to www.parker.com, for telephone numbers of the appropriate technical service department.

2. PRODUCT SELECTION INSTRUCTIONS

- 2.1. **Flow Rate:** The flow rate requirements of a system are frequently the primary consideration when designing any pneumatic system. System components need to be able to provide adequate flow and pressure for the desired application.
- 2.2. **Pressure Rating:** Never exceed the rated pressure of a product. Consult product labeling, Pneumatic Division catalogs or the instruction sheets supplied for Maximum pressure ratings.
- 2.3. **Temperature Rating:** Never exceed the temperature rating of a product. Excessive heat can shorten the life expectancy of a product and result in complete product failure.
- 2.4. **Environment:** Many environmental conditions can affect the integrity and suitability of a product for a given application. Pneumatic Division products are designed for use in general purpose industrial applications. If these products are to be used in unusual circumstances such as direct sunlight and/or corrosive or caustic environments, such use can shorten the useful life and lead to premature failure of a product.
- 2.5. **Lubrication and Compressor Carryover:** Some modern synthetic oils can and will attack nitrile seals. If there is any possibility of synthetic oils or greases migrating into the pneumatic components check for compatibility with the seal materials used. Consult the factory or product literature for materials of construction.
- 2.6. **Polycarbonate Bowls and Sight Gauges:** To avoid potential polycarbonate bowl failures:
 - Do not locate polycarbonate bowls or sight gauges in areas where they could be subject to direct sunlight, impact blow, or temperatures outside of the rated range.
 - Do not expose or clean polycarbonate bowls with detergents, chlorinated hydro-carbons, ketones, esters or certain alcohols.

- Do not use polycarbonate bowls or sight gauges in air systems where compressors are lubricated with fire resistant fluids such as phosphate ester and di-ester lubricants.
- 2.7. **Chemical Compatibility:** For more information on plastic component chemical compatibility see Pneumatic Division technical bulletins Tec-3, Tec-4, and Tec-5
 - 2.8. **Product Rupture:** Product rupture can cause death, serious personal injury, and property damage.
 - Do not connect pressure regulators or other Pneumatic Division products to bottled gas cylinders.
 - Do not exceed the Maximum primary pressure rating of any pressure regulator or any system component.
 - Consult product labeling or product literature for pressure rating limitations.

3. PRODUCT ASSEMBLY AND INSTALLATION INSTRUCTIONS

- 3.1. **Component Inspection:** Prior to assembly or installation a careful examination of the valves, FRLs or vacuum products must be performed. All components must be checked for correct style, size, and catalog number. DO NOT use any component that displays any signs of nonconformance.
- 3.2. **Installation Instructions:** Parker published Installation Instructions must be followed for installation of Parker valves, FRLs and vacuum components. These instructions are provided with every Parker valve or FRL sold, or by calling 1-800-CPARKER, or at www.parker.com.
- 3.3. **Air Supply:** The air supply or control medium supplied to Valves, FRLs and Vacuum components must be moisture-free if ambient temperature can drop below freezing

4. VALVE AND FRL MAINTENANCE AND REPLACEMENT INSTRUCTIONS

- 4.1. **Maintenance:** Even with proper selection and installation, valve, FRL and vacuum products service life may be significantly reduced without a continuing maintenance program. The severity of the application, risk potential from a component failure, and experience with any known failures in the application or in similar applications should determine the frequency of inspections and the servicing or replacement of Pneumatic Division products so that products are replaced before any failure occurs. A maintenance program must be established and followed by the user and, at Minimum, must include instructions 4.2 through 4.10.
- 4.2. **Installation and Service Instructions:** Before attempting to service or replace any worn or damaged parts consult the appropriate Service Bulletin for the valve or FRL in question for the appropriate practices to service the unit in question. These Service and Installation Instructions are provided with every Parker valve and FRL sold, or are available by calling 1-800-CPARKER, or by accessing the Parker web site at www.parker.com.
- 4.3. **Lockout / Tagout Procedures:** Be sure to follow all required lockout and tagout procedures when servicing equipment. For more information see: OSHA Standard – 29 CFR, Part 1910.147, Appendix A, The Control of Hazardous Energy – (Lockout / Tagout)
- 4.4. **Visual Inspection:** Any of the following conditions requires immediate system shut down and replacement of worn or damaged components:
 - Air leakage: Look and listen to see if there are any signs of visual damage to any of the components in the system. Leakage is an indication of worn or damaged components.
 - Damaged or degraded components: Look to see if there are any visible signs of wear or component degradation.
 - Kinked, crushed, or damaged hoses. Kinked hoses can result in restricted air flow and lead to unpredictable system behavior.
 - Any observed improper system or component function: Immediately shut down the system and correct malfunction.
 - Excessive dirt build-up: Dirt and clutter can mask potentially hazardous situations.
- Caution: Leak detection solutions should be rinsed off after use.
- 4.5. **Routine Maintenance Issues:**
 - Remove excessive dirt, grime and clutter from work areas.
 - Make sure all required guards and shields are in place.
- 4.6. **Functional Test:** Before initiating automatic operation, operate the system manually to make sure all required functions operate properly and safely.
- 4.7. **Service or Replacement Intervals:** It is the user's responsibility to establish appropriate service intervals. Valves, FRLs and vacuum products contain components that age, harden, wear, and otherwise deteriorate over time. Environmental conditions can significantly accelerate this process. Valves, FRLs and vacuum

components need to be serviced or replaced on routine intervals. Service intervals need to be established based on:

- Previous performance experiences.
- Government and / or industrial standards.
- When failures could result in unacceptable down time, equipment damage or personal injury risk.

- 4.8. **Servicing or Replacing of any Worn or Damaged Parts:** To avoid unpredictable system behavior that can cause death, personal injury and property damage:
- Follow all government, state and local safety and servicing practices prior to service including but not limited to all OSHA Lockout Tagout procedures (OSHA Standard – 29 CFR, Part 1910.147, Appendix A, The Control of Hazardous Energy – Lockout / Tagout).
 - Disconnect electrical supply (when necessary) before installation, servicing, or conversion.
 - Disconnect air supply and depressurize all air lines connected to system and Pneumatic Division products before installation, service, or conversion.
 - Installation, servicing, and / or conversion of these products must be performed by knowledgeable personnel who understand how pneumatic products are to be applied.
 - After installation, servicing, or conversions air and electrical supplies (when necessary) should be connected and the product tested for proper function and leakage. If audible leakage is present, or if the product does not operate properly, do not put product or system into use.
 - Warnings and specifications on the product should not be covered or painted over. If masking is not possible, contact your local representative for replacement labels.
- 4.9. **Putting Serviced System Back into Operation:** Follow the guidelines above and all relevant Installation and Maintenance Instructions supplied with the valve FRL or vacuum component to insure proper function of the system.

Parker Safety Guide for Selecting and Using Hose, Tubing, Fittings, Connectors, Conductors, Valves and Related Accessories

Parker Publication No. 4400-B.1

WARNING: Failure or improper selection or improper use of hose, tubing, fittings, assemblies, valves, connectors, conductors or related accessories ("Products") can cause death, personal injury and property damage. Possible consequences of failure or improper selection or improper use of these Products include but are not limited to:

- Fittings thrown off at high speed.
- High velocity fluid discharge.
- Explosion or burning of the conveyed fluid.
- Electrocutation from high voltage electric powerlines.
- Contact with suddenly moving or falling objects that are controlled by the conveyed fluid.
- Injections by high-pressure fluid discharge.
- Dangerously whipping Hose.
- Tube or pipe burst.
- Weld joint fracture.
- Contact with conveyed fluids that may be hot, cold, toxic or otherwise injurious.
- Sparking or explosion caused by static electricity buildup or other sources of electricity.
- Sparking or explosion while spraying paint or flammable liquids.
- Injuries resulting from inhalation, ingestion or exposure to fluids.

Before selecting or using any of these Products, it is important that you read and follow the instructions below. No product from any division in Fluid Connector Group is approved for in-flight aerospace applications. For hoses and fittings used in in-flight aerospace applications, please contact Parker Aerospace Group

GENERAL INSTRUCTIONS

- 1.0 Scope:** This safety guide provides instructions for selecting and using (including assembling, installing, and maintaining) these Products. For convenience, all rubber and/or thermoplastic products commonly called "hose" or "tubing" are called "Hose" in this safety guide. Metallic tube or pipe are called "tube". All assemblies made with Hose are called "Hose Assemblies". All assemblies made with Tube are called "Tube Assemblies". All products commonly called "fittings", "couplings" or "adapters" are called "Fittings". Valves are fluid system components that control the passage of fluid. Related accessories are ancillary devices that enhance or monitor performance including crimping, flaring, flanging, presetting, bending, cutting, deburring, swaging machines, sensors, tags, lockout handles, spring guards and associated tooling. This safety guide is a supplement to and is to be used with the specific Parker publications for the specific Hose, Fittings and Related Accessories that are being considered for use. Parker publications are available at www.parker.com. SAE J1273 (www.sae.org) and ISO 17165-2 (www.ansi.org) also provide recommended practices for hydraulic Hose Assemblies, and should be followed.
- 1.1 Fail-Safe:** Hose, Hose Assemblies, Tube, Tube Assemblies and Fittings can and do fail without warning for many reasons. Design all systems and equipment in a fail-safe mode, so that failure of the Hose, Hose Assembly, Tube, Tube Assembly or Fitting will not endanger persons or property.
- 1.2 Distribution:** Provide a copy of this safety guide to each person responsible for selecting or using Hose, Tube and Fitting products. Do not select or use Parker Hose, Tube or Fittings without thoroughly reading and understanding this safety guide as well as the specific Parker publications for the Products.
- 1.3 User Responsibility:** Due to the wide variety of operating conditions and applications for Hose, Tube and Fittings. Parker does not represent or warrant that any particular Hose, Tube or Fitting is suitable for any specific end use system. This safety guide does not analyze all technical parameters that must be considered in selecting a product. The user, through its own analysis and testing, is solely responsible for:
- Making the final selection of the Products.
 - Assuring that the user's requirements are met and that the application presents no health or safety hazards.
 - Following the safety guide for Related Accessories and being trained to operate Related Accessories.
 - Providing all appropriate health and safety warnings on the equipment on which the Products are used.
 - Assuring compliance with all applicable government and industry standards.
- 1.4 Additional Questions:** Call the appropriate Parker technical service department if you have any questions or require any additional information. See the Parker publication for the Products being considered or used, or call 1-800-CPARKER, or go to www.parker.com, for telephone numbers of the appropriate technical service department.

2.0 HOSE, TUBE AND FITTINGS SELECTION INSTRUCTIONS

- 2.1 Electrical Conductivity:** Certain applications require that the Hose be nonconductive to prevent electrical current flow. Other applications require the Hose and the Fittings and the Hose/Fitting interface to be sufficiently conductive to drain off static electricity. Extreme care must be exercised when selecting Hose, Tube and Fittings for these or any other applications in which electrical conductivity or nonconductivity is a factor.
- The electrical conductivity or nonconductivity of Hose, Tube and Fittings is dependent upon many factors and may be susceptible to change. These factors include but are not limited to the various materials used to make the Hose and the Fittings, Fitting finish (some Fitting finishes are electrically conductive while others are nonconductive), manufacturing methods (including moisture control), how the Fittings contact the Hose, age and amount of deterioration or damage or other changes, moisture content of the Hose at any particular time, and other factors.
- The following are considerations for electrically nonconductive and conductive Hose. For other applications consult the individual catalog pages and the appropriate industry or regulatory standards for proper selection.
- 2.1.1 Electrically Nonconductive Hose:** Certain applications require that the Hose be nonconductive to prevent electrical current flow or to maintain

electrical isolation. For applications that require Hose to be electrically nonconductive, including but not limited to applications near high voltage electric lines, only special nonconductive Hose can be used. The manufacturer of the equipment in which the nonconductive Hose is to be used must be consulted to be certain that the Hose, Tube and Fittings that are selected are proper for the application. Do not use any Parker Hose or Fittings for any such application requiring nonconductive Hose, including but not limited to applications near high voltage electric lines or dense magnetic fields, unless (i) the application is expressly approved in the Parker technical publication for the product, (ii) the Hose is marked "nonconductive", and (iii) the manufacturer of the equipment on which the Hose is to be used specifically approves the particular Parker Hose, Tube and Fittings for such use.

- 2.1.2 Electrically Conductive Hose:** Parker manufactures special Hose for certain applications that require electrically conductive Hose. Parker manufactures special Hose for conveying paint in airless paint spraying applications. This Hose is labeled "Electrically Conductive Airless Paint Spray Hose" on its layline and packaging. This Hose must be properly connected to the appropriate Parker Fittings and properly grounded in order to dissipate dangerous static charge buildup, which occurs in all airless paint spraying applications. Do not use any other Hose for airless paint spraying, even if electrically conductive. Use of any other Hose or failure to properly connect the Hose can cause a fire or an explosion resulting in death, personal injury, and property damage. All hoses that convey fuels must be grounded. Parker manufactures a special Hose for certain compressed natural gas ("CNG") applications where static electricity buildup may occur. Parker CNG Hose assemblies comply with the requirements of ANSI/IAS NGV 4.2; CSA 12.52, "Hoses for Natural Gas Vehicles and Dispensing Systems" (www.ansi.org). This Hose is labeled "Electrically Conductive for CNG Use" on its layline and packaging. This Hose must be properly connected to the appropriate Parker Fittings and properly grounded in order to dissipate dangerous static charge buildup, which occurs in, for example, high velocity CNG dispensing or transfer. Do not use any other Hose for CNG applications where static charge buildup may occur, even if electrically conductive. Use of other Hoses in CNG applications or failure to properly connect or ground this Hose can cause a fire or an explosion resulting in death, personal injury, and property damage. Care must also be taken to protect against CNG permeation through the Hose wall. See section 2.6, Permeation, for more information. Parker CNG Hose is intended for dispenser and vehicle use within the specified temperature range. Parker CNG Hose should not be used in confined spaces or unventilated areas or areas exceeding the specified temperature range. Final assemblies must be tested for leaks. CNG Hose Assemblies should be tested on a monthly basis for conductivity per ANSI/IAS NGV 4.2; CSA 12.52. Parker manufactures special Hose for aerospace in-flight applications. Aerospace in-flight applications employing Hose to transmit fuel, lubricating fluids and hydraulic fluids require a special Hose with a conductive inner tube. This Hose for in-flight applications is available only from Parker's Stratoflex Products Division. Do not use any other Parker Hose for in-flight applications, even if electrically conductive. Use of other Hoses for in-flight applications or failure to properly connect or ground this Hose can cause a fire or an explosion resulting in death, personal injury and property damage. These Hose assemblies for in-flight applications must meet all applicable aerospace industry, aircraft engine and aircraft requirements.
- 2.2 Pressure:** Hose, Tube and Fitting selection must be made so that the published maximum working pressure of the Hose, Tube and Fittings are equal to or greater than the maximum system pressure. The maximum working pressure of a Hose, or Tube Assembly is the lower of the respective published maximum working pressures of the Hose, Tube and the Fittings used. Surge pressures or peak transient pressures in the system must be below the published maximum working pressure for the Hose, Tube and Fitting. Surge pressures and peak pressures can usually only be determined by sensitive electrical instrumentation that measures and indicates pressures at millisecond intervals. Mechanical pressure gauges indicate only average pressures and cannot be used to determine surge pressures or peak transient pressures. Published burst pressure ratings for Hose is for manufacturing test purposes only and is no indication that the Product can be used in applications at the burst pressure or otherwise above the published

- maximum recommended working pressure.
- 2.3 **Suction:** Hoses used for suction applications must be selected to insure that the Hose will withstand the vacuum and pressure of the system. Improperly selected Hose may collapse in suction application.
- 2.4 **Temperature:** Be certain that fluid and ambient temperatures, both steady and transient, do not exceed the limitations of the Hose, Tube, Fitting and Seals. Temperatures below and above the recommended limit can degrade Hose, Tube, Fittings and Seals to a point where a failure may occur and release fluid. Tube and Fittings performances are normally degraded at elevated temperature. Material compatibility can also change at temperatures outside of the rated range. Properly insulate and protect the Hose Assembly when routing near hot objects (e.g. manifolds). Do not use any Hose in any application where failure of the Hose could result in the conveyed fluids (or vapors or mist from the conveyed fluids) contacting any open flame, molten metal, or other potential fire ignition source that could cause burning or explosion of the conveyed fluids or vapors.
- 2.5 **Fluid Compatibility:** Hose, and Tube Assembly selection must assure compatibility of the Hose tube, cover, reinforcement, Tube, Plating and Seals with the fluid media used. See the fluid compatibility chart in the Parker publication for the product being considered or used. This information is offered only as a guide. Actual service life can only be determined by the end user by testing under all extreme conditions and other analysis. Hose, and Tube that is chemically compatible with a particular fluid must be assembled using Fittings and adapters containing likewise compatible seals. Flange or flare processes can change Tube material properties that may not be compatible with certain requirements such as NACE
- 2.6 **Permeation:** Permeation (that is, seepage through the Hose or Seal) will occur from inside the Hose or Fitting to outside when Hose or Fitting is used with gases, liquid and gas fuels, and refrigerants (including but not limited to such materials as helium, diesel fuel, gasoline, natural gas, or LPG). This permeation may result in high concentrations of vapors which are potentially flammable, explosive, or toxic, and in loss of fluid. Dangerous explosions, fires, and other hazards can result when using the wrong Hose for such applications. The system designer must take into account the fact that this permeation will take place and must not use Hose or Fitting if this permeation could be hazardous. The system designer must take into account all legal, government, insurance, or any other special regulations which govern the use of fuels and refrigerants. Never use a Hose or Fitting even though the fluid compatibility is acceptable without considering the potential hazardous effects that can result from permeation through the Hose or Tube Assembly. Permeation of moisture from outside the Hose or Fitting to inside the Hose or Fitting will also occur in Hose or Tube assemblies, regardless of internal pressure. If this moisture permeation would have detrimental effects (particularly, but not limited to refrigeration and air conditioning systems), incorporation of sufficient drying capacity in the system or other appropriate system safeguards should be selected and used. The sudden pressure release of highly pressurized gas could also result in Explosive Decompression failure of permeated Seals and Hoses.
- 2.7 **Size:** Transmission of power by means of pressurized fluid varies with pressure and rate of flow. The size of the components must be adequate to keep pressure losses to a minimum and avoid damage due to heat generation or excessive fluid velocity.
- 2.8 **Routing:** Attention must be given to optimum routing to minimize inherent problems (kinking or flow restriction due to Hose collapse, twisting of the Hose, proximity to hot objects or heat sources). For additional routing recommendations see SAE J1273 and ISO 17165-2. Hose Assemblies have a finite life and should be installed in a manner that allows for ease of inspection and future replacement. Hose because of its relative short life, should not be used in residential and commercial buildings inside of inaccessible walls or floors, unless specifically allowed in the product literature. Always review all product literature for proper installation and routing instructions.
- 2.9 **Environment:** Care must be taken to insure that the Hose, Tube and Fittings are either compatible with or protected from the environment (that is, surrounding conditions) to which they are exposed. Environmental conditions including but not limited to ultraviolet radiation, sunlight, heat, ozone, moisture, water, salt water, chemicals and air pollutants can cause degradation and premature failure.
- 2.10 **Mechanical Loads:** External forces can significantly reduce Hose, Tube and Fitting life or cause failure. Mechanical loads which must be considered include excessive flexing, twist, kinking, tensile or side loads, bend radius, and vibration. Use of swivel type Fittings or adapters may be required to insure no twist is put into the Hose. Use of proper Hose or Tube clamps may also be required to reduce external mechanical loads. Unusual applications may require special testing prior to Hose selection.
- 2.11 **Physical Damage:** Care must be taken to protect Hose from wear, snagging, kinking, bending smaller than minimum bend radius and cutting, any of which can cause premature Hose failure. Any Hose that has been kinked or bent to a radius smaller than the minimum bend radius, and any Hose that has been cut or is cracked or is otherwise damaged should be removed and discarded. Fittings with damages such as scratches on sealing surfaces and deformation should be replaced.
- 2.12 **Proper End Fitting:** See instructions 3.2 through 3.5. These recommendations may be substantiated by testing to industry standards such as SAE J517 for hydraulic applications, or MIL-A-5070, AS1339, or AS3517 for Hoses from Parker's Stratoflex Products Division for aerospace applications.
- 2.13 **Length:** When determining the proper Hose or Tube length of an assembly, be aware of Hose length change due to pressure, Tube length change due to thermal expansion or contraction, and Hose or Tube and machine tolerances and movement must be considered. When routing short hose assemblies, it is recommended that the minimum free hose length is always used. Consult the hose manufacturer for their minimum free hose length recommendations. Hose assemblies should be installed in such a way that any motion or flexing occurs within the same plane.
- 2.14 **Specifications and Standards:** When selecting Hose, Tube and Fittings, government, industry, and Parker specifications and recommendations must be reviewed and followed as applicable.
- 2.15 **Hose Cleanliness:** Hose and Tube components may vary in cleanliness levels. Care must be taken to insure that the Hose and Tube Assembly selected has an adequate level of cleanliness for the application.
- 2.16 **Fire Resistant Fluids:** Some fire resistant fluids that are to be conveyed by Hose or Tube require use of the same type of Hose or Tube as used with petroleum base fluids. Some such fluids require a special Hose, Tube, Fitting and Seal, while a few fluids will not work with any Hose at all. See instructions 2.5 and 1.5. The wrong Hose, Tube, Fitting or Seal may fail after a very short service. In addition, all liquids but pure water may burn fiercely under certain conditions, and even pure water leakage may be hazardous.
- 2.17 **Radiant Heat:** Hose and Seals can be heated to destruction without contact by such nearby items as hot manifolds or molten metal. The same heat source may then initiate a fire. This can occur despite the presence of cool air around the Hose or Seal. Performance of Tube and Fitting subjected to the heat could be degraded.
- 2.18 **Welding or Brazing:** When using a torch or arc welder in close proximity to hydraulic lines, the hydraulic lines should be removed or shielded with appropriate fire resistant materials. Flame or weld spatter could burn through the Hose or Seal and possibly ignite escaping fluid resulting in a catastrophic failure. Heating of plated parts, including Hose Fittings and adapters, above 450°F (232°C) such as during welding, brazing or soldering may emit deadly gases. Any elastomer seal on fittings shall be removed prior to welding or brazing, any metallic surfaces shall be protected after brazing or welding when necessary. Welding and brazing filler material shall be compatible with the Tube and Fitting that are joined.
- 2.19 **Atomic Radiation:** Atomic radiation affects all materials used in Hose and Tube assemblies. Since the long-term effects may be unknown, do not expose Hose or Tube assemblies to atomic radiation. Nuclear applications may require special Tube and Fittings.
- 2.20 **Aerospace Applications:** The only Hose, Tube and Fittings that may be used for in-flight aerospace applications are those available from Parker's Stratoflex Products Division. Do not use any other Hose or Fittings for in-flight applications. Do not use any Hose or Fittings from Parker's Stratoflex Products Division with any other Hose or Fittings, unless expressly approved in writing by the engineering manager or chief engineer of Stratoflex Products Division and verified by the user's own testing and inspection to aerospace industry standards.
- 2.21 **Unlocking Couplings:** Ball locking couplings or other Fittings with quick disconnect ability can unintentionally disconnect if they are dragged over obstructions, or if the sleeve or other disconnect member, is bumped or moved enough to cause disconnect. Threaded Fittings should be considered where there is a potential for accidental uncoupling.

3.0 HOSE AND FITTINGS ASSEMBLY AND INSTALLATION INSTRUCTIONS

- 3.1 **Component Inspection:** Prior to assembly, a careful examination of the Hose and Fittings must be performed. All components must be checked for correct style, size, catalog number, and length. The Hose must be examined for cleanliness, obstructions, blisters, cover looseness, kinks, cracks, cuts or any other visible defects. Inspect the Fitting and sealing surfaces for burrs, nicks, corrosion or other imperfections. Do NOT use any component that displays any signs of nonconformance.
- 3.2 **Hose and Fitting Assembly:** Do not assemble a Parker Fitting on a Parker Hose that is not specifically listed by Parker for that Fitting, unless authorized in writing by the engineering manager or chief engineer of the appropriate Parker division. Do not assemble a Parker Fitting on another manufacturer's Hose or a Parker Hose on another manufacturer's Fitting unless (i) the engineering manager or chief engineer of the appropriate Parker division approves the Assembly in writing or that combination is expressly approved in the appropriate Parker literature for the specific Parker product, and (ii) the user verifies the Assembly and the application through analysis and testing. For Parker Hose that does not specify a Parker Fitting, the user is solely responsible for the selection of the proper Fitting and Hose Assembly procedures. See instruction 1.4. To prevent the possibility of problems such as leakage at the Fitting or system contamination, it is important to completely remove all debris from the cutting operation before installation of the Fittings. The Parker published instructions must be followed for assembling the Fittings on the Hose. These instructions are provided in the Parker Fitting catalog for the specific Parker Fitting being used, or by calling 1-800-CPARKER, or at www.parker.com.
- 3.3 **Related Accessories:** Do not crimp or swage any Parker Hose or Fitting with anything but the listed swage or crimp machine and dies in accordance with Parker published instructions. Do not crimp or swage another manufacturer's Fitting with a Parker crimp or swage die unless authorized in writing by the engineering manager or chief engineer of the appropriate Parker division.
- 3.4 **Parts:** Do not use any Parker Fitting part (including but not limited to socket, shell, nipple, or insert) except with the correct Parker mating parts, in accordance with Parker published instructions, unless authorized in writing by the engineering manager or chief engineer of the appropriate Parker division.
- 3.5 **Field Attachable/Permanent:** Do not reuse any field attachable Hose Fitting that has blown or pulled off a Hose. Do not reuse a Parker permanent Hose Fitting (crimped or swaged) or any part thereof. Complete Hose Assemblies may only be reused after proper inspection under section 4.0. Do not assemble Fittings to any previously used hydraulic Hose that was in service, for use in a fluid power application.
- 3.6 **Pre-Installation Inspection:** Prior to installation, a careful examination of the Hose Assembly must be performed. Inspect the Hose Assembly for any damage or defects. DO NOT use any Hose Assembly that displays any signs of nonconformance.
- 3.7 **Minimum Bend Radius:** Installation of a Hose at less than the minimum listed bend radius may significantly reduce the Hose life. Particular attention must be given to preclude sharp bending at the Hose to Fitting juncture. Any bending during installation at less than the minimum bend radius must be avoided. If any Hose is kinked during installation, the Hose must be discarded.
- 3.8 **Twist Angle and Orientation:** Hose Assembly installation must be such that relative motion of machine components does not produce twisting.
- 3.9 **Securement:** In many applications, it may be necessary to restrain, protect, or guide the Hose to protect it from damage by unnecessary flexing, pressure surges, and contact with other mechanical components. Care must be taken to insure such restraints do not introduce additional stress or wear points.

- 3.10 **Proper Connection of Ports:** Proper physical installation of the Hose Assembly requires a correctly installed port connection insuring that no twist or torque is transferred to the Hose when the Fittings are being tightened or otherwise during use.
- 3.11 **External Damage:** Proper installation is not complete without insuring that tensile loads, side loads, kinking, flattening, potential abrasion, thread damage or damage to sealing surfaces are corrected or eliminated. See instruction 2.10.
- 3.12 **System Checkout:** All air entrapment must be eliminated and the system pressurized to the maximum system pressure (at or below the Hose maximum working pressure) and checked for proper function and freedom from leaks. Personnel must stay out of potential hazardous areas while testing and using.
- 3.13 **Routing:** The Hose Assembly should be routed in such a manner so if a failure does occur, the escaping media will not cause personal injury or property damage. In addition, if fluid media comes in contact with hot surfaces, open flame or sparks, a fire or explosion may occur. See section 2.4.
- 3.14 **Ground Fault Equipment Protection Devices (GFEPDs):** WARNING! Fire and Shock Hazard. To minimize the danger of fire if the heating cable of a Multitube bundle is damaged or improperly installed, use a Ground Fault Equipment Protection Device. Electrical fault currents may be insufficient to trip a conventional circuit breaker. For ground fault protection, the IEEE 515: (www.ansi.org) standard for heating cables recommends the use of GFEPDs with a nominal 30 milliamperere trip level for "piping systems in classified areas, those areas requiring a high degree of maintenance, or which may be exposed to physical abuse or corrosive atmospheres".

4.0 TUBE AND FITTINGS ASSEMBLY AND INSTALLATION INSTRUCTIONS

- 4.1 **Component Inspection:** Prior to assembly, a careful examination of the Tube and Fittings must be performed. All components must be checked for correct style, size, material, seal, and length. Inspect the Fitting and sealing surfaces for burrs, nicks, corrosion, missing seal or other imperfections. Do NOT use any component that displays any signs of nonconformance.
- 4.2 **Tube and Fitting Assembly:** Do not assemble a Parker Fitting with a Tube that is not specifically listed by Parker for that Fitting, unless authorized in writing by the engineering manager or chief engineer of the appropriate Parker division. The Tube must meet the requirements specified to the Fitting. The Parker published instructions must be followed for assembling the Fittings to a Tube. These instructions are provided in the Parker Fitting catalog for the specific Parker Fitting being used, or by calling 1-800-CPARKER, or at www.parker.com.
- 4.3 **Related Accessories:** Do not preset or flange Parker Fitting components using another manufacturer's equipment or procedures unless authorized in writing by the engineering manager or chief engineer of the appropriate Parker division. Tube, Fitting component and tooling must be checked for correct style, size and material. Operation and maintenance of Related Accessories must be in accordance with the operation manual for the designated Accessory.
- 4.4 **Securement:** In many applications, it may be necessary to restrain, protect, or guide the Tube to protect it from damage by unnecessary flexing, pressure surges, vibration, and contact with other mechanical components. Care must be taken to insure such restraints do not introduce additional stress or wear points.
- 4.5 **Proper Connection of Ports:** Proper physical installation of the Tube Assembly requires a correctly installed port connection insuring that no torque is transferred to the Tube when the Fittings are being tightened or otherwise during use.
- 4.6 **External Damage:** Proper installation is not complete without insuring that tensile loads, side loads, flattening, potential abrasion, thread damage or damage to sealing surfaces are corrected or eliminated. See instruction 2.10.
- 4.7 **System Checkout:** All air entrapment must be eliminated and the system pressurized to the maximum system pressure (at or below the Tube Assembly maximum working pressure) and checked for proper function and freedom from leaks. Personnel must stay out of potential hazardous areas while testing and using.
- 4.8 **Routing:** The Tube Assembly should be routed in such a manner so if a failure does occur, the escaping media will not cause personal injury or property damage. In addition, if fluid media comes in contact with hot surfaces, open flame or sparks, a fire or explosion may occur. See section 2.4.

5.0 HOSE AND FITTING MAINTENANCE AND REPLACEMENT INSTRUCTIONS

- 5.1 Even with proper selection and installation, Hose life may be significantly reduced without a continuing maintenance program. The severity of the application, risk potential from a possible Hose failure, and experience with any Hose failures in the application or in similar applications should determine the frequency of the inspection and the replacement for the Products so that Products are replaced before any failure occurs. Certain products require maintenance and inspection per industry requirements. Failure to adhere to these requirements may lead to premature failure. A maintenance program must be established and followed by the user and, at minimum, must include instructions 5.2 through 5.7
- 5.2 **Visual Inspection Hose/Fitting:** Any of the following conditions require immediate shut down and replacement of the Hose Assembly:
- Fitting slippage on Hose;
 - Damaged, cracked, cut or abraded cover (any reinforcement exposed);
 - Hard, stiff, heat cracked, or charred Hose;
 - Cracked, damaged, or badly corroded Fittings;
 - Leaks at Fitting or in Hose;
 - Kinked, crushed, flattened or twisted Hose; and
 - Blistered, soft, degraded, or loose cover.
- 5.3 **Visual Inspection All Other:** The following items must be tightened, repaired, corrected or replaced as required:
- Leaking port conditions;
 - Excess dirt buildup;
 - Worn clamps, guards or shields; and
 - System fluid level, fluid type, and any air entrapment.
- 5.4 **Functional Test:** Operate the system at maximum operating pressure and check for possible malfunctions and leaks. Personnel must avoid potential hazardous areas while testing and using the system. See section 2.2.
- 5.5 **Replacement Intervals:** Hose assemblies and elastomeric seals used on Hose

Fittings and adapters will eventually age, harden, wear and deteriorate under thermal cycling and compression set. Hose Assemblies and elastomeric seals should be inspected and replaced at specific replacement intervals, based on previous service life, government or industry recommendations, or when failures could result in unacceptable downtime, damage, or injury risk. See section 1.2. Hose and Fittings may be subjected to internal mechanical and/or chemical wear from the conveying fluid and may fail without warning. The user must determine the product life under such circumstances by testing. Also see section 2.5.

- 5.6 **Hose Inspection and Failure:** Hydraulic power is accomplished by utilizing high pressure fluids to transfer energy and do work. Hoses, Fittings and Hose Assemblies all contribute to this by transmitting fluids at high pressures. Fluids under pressure can be dangerous and potentially lethal and, therefore, extreme caution must be exercised when working with fluids under pressure and handling the Hoses transporting the fluids. From time to time, Hose Assemblies will fail if they are not replaced at proper time intervals. Usually these failures are the result of some form of misapplication, abuse, wear or failure to perform proper maintenance. When Hoses fail, generally the high pressure fluids inside escape in a stream which may or may not be visible to the user. Under no circumstances should the user attempt to locate the leak by "feeling" with their hands or any other part of their body. High pressure fluids can and will penetrate the skin and cause severe tissue damage and possibly loss of limb. Even seemingly minor hydraulic fluid injection injuries must be treated immediately by a physician with knowledge of the tissue damaging properties of hydraulic fluid. If a Hose failure occurs, immediately shut down the equipment and leave the area until pressure has been completely released from the Hose Assembly. Simply shutting down the hydraulic pump may or may not eliminate the pressure in the Hose Assembly. Many times check valves, etc., are employed in a system and can cause pressure to remain in a Hose Assembly even when pumps or equipment are not operating. Tiny holes in the Hose, commonly known as pinholes, can eject small, dangerously powerful but hard to see streams of hydraulic fluid. It may take several minutes or even hours for the pressure to be relieved so that the Hose Assembly may be examined safely. Once the pressure has been reduced to zero, the Hose Assembly may be taken off the equipment and examined. It must always be replaced if a failure has occurred. Never attempt to patch or repair a Hose Assembly that has failed. Consult the nearest Parker distributor or the appropriate Parker division for Hose Assembly replacement information. Never touch or examine a failed Hose Assembly unless it is obvious that the Hose no longer contains fluid under pressure. The high pressure fluid is extremely dangerous and can cause serious and potentially fatal injury.
- 5.7 **Elastomeric seals:** Elastomeric seals will eventually age, harden, wear and deteriorate under thermal cycling and compression set. Elastomeric seals should be inspected and replaced.
- 5.8 **Refrigerant gases:** Special care should be taken when working with refrigeration systems. Sudden escape of refrigerant gases can cause blindness if the escaping gases contact the eye and can cause freezing or other severe injuries if it contacts any other portion of the body.
- 5.9 **Compressed natural gas (CNG):** Parker CNG Hose Assemblies should be tested after installation and before use, and at least on a monthly basis per instructions provided on the Hose Assembly tag. The recommended procedure is to pressurize the Hose and check for leaks and to visually inspect the Hose for damage and to perform an electrical resistance test. Caution: Matches, candles, open flame or other sources of ignition shall not be used for Hose inspection. Leak check solutions should be rinsed off after use.

6.0 HOSE STORAGE

- 6.1 **Age Control:** Hose and Hose Assemblies must be stored in a manner that facilitates age control and first-in and first-out usage based on manufacturing date of the Hose and Hose Assemblies. Unless otherwise specified by the manufacturer or defined by local laws and regulations:
- 6.1.1 The shelf life of rubber hose in bulk form or hose made from two or more materials is 28 quarters (7 years) from the date of manufacture, with an extension of 12 quarters (3 years), if stored in accordance with ISO 2230;
- 6.1.2 The shelf life of thermoplastic and polytetrafluoroethylene hose is considered to be unlimited;
- 6.1.3 Hose assemblies that pass visual inspection and proof test shall not be stored for longer than 2 years.
- 6.1.4 **Storage:** Stored Hose and Hose Assemblies must not be subjected to damage that could reduce their expected service life and must be placed in a cool, dark and dry area with the ends capped. Stored Hose and Hose Assemblies must not be exposed to temperature extremes, ozone, oils, corrosive liquids or fumes, solvents, high humidity, rodents, insects, ultraviolet light, electromagnetic fields or radioactive materials.

Parker's Motion & Control Product Groups

At Parker, we're guided by a relentless drive to help our customers become more productive and achieve higher levels of profitability by engineering the best systems for their requirements. It means looking at customer applications from many angles to find new ways to create value. Whatever the motion and control technology need, Parker has the experience, breadth of product and global reach to consistently deliver. No company knows more about motion and control technology than Parker. For further info call 1 800 C-Parker (1 800 272 7537).



Aerospace

Key Markets

Aftermarket services
Commercial transports
Engines
General & business aviation
Helicopters
Launch vehicles
Military aircraft
Missiles
Power generation
Regional transports
Unmanned aerial vehicles

Key Products

Control systems & actuation products
Engine systems & components
Fluid conveyance systems & components
Fluid metering, delivery & atomization devices
Fuel systems & components
Fuel tank inerting systems
Hydraulic systems & components
Thermal management
Wheels & brakes



Automation

Key Markets

Alternative energy
Conveyor & material handling
Factory automation
Food & beverage
Life sciences & medical
Machine tools
Packaging machinery
Paper machinery
Plastics machinery
Primary metals
Safety & security
Semiconductor & electronics
Transportation & automotive

Key Products

AC/DC drives & systems
Air preparation
Electric actuators, gantry robots & slides
Human machine interfaces
Inverters
Manifolds
Miniature fluidics
Pneumatic actuators & grippers
Pneumatic valves & controls
Rotary actuators
Stepper motors, servo motors, drives & controls
Structural extrusions
Vacuum generators, cups & sensors



Climate & Industrial Controls

Key Markets

Agriculture
Air conditioning
Construction Machinery
Food & beverage
Industrial machinery
Life sciences
Oil & gas
Precision cooling
Process
Refrigeration
Transportation

Key Products

Accumulators
Advanced actuators
CO₂ controls
Electronic controllers
Filter driers
Hand shut-off valves
Heat exchangers
Hose & fittings
Pressure regulating valves
Refrigerant distributors
Safety relief valves
Smart pumps
Solenoid valves
Thermostatic expansion valves



Filtration

Key Markets

Aerospace
Food & beverage
Industrial plant & equipment
Life sciences
Marine
Mobile equipment
Oil & gas
Power generation & renewable energy
Process
Transportation
Water Purification

Key Products

Analytical gas generators
Compressed air filters & dryers
Engine air, coolant, fuel & oil filtration systems
Fluid condition monitoring systems
Hydraulic & lubrication filters
Hydrogen, nitrogen & zero air generators
Instrumentation filters
Membrane & fiber filters
Microfiltration
Sterile air filtration
Water desalination & purification filters & systems



Fluid Connectors

Key Markets

Aerial lift
Agriculture
Bulk chemical handling
Construction machinery
Food & beverage
Fuel & gas delivery
Industrial machinery
Life sciences
Marine
Mining
Mobile
Oil & gas
Renewable energy
Transportation

Key Products

Check valves
Connectors for low pressure fluid conveyance
Deep sea umbilicals
Diagnostic equipment
Hose couplings
Industrial hose
Mooring systems & power cables
PTFE hose & tubing
Quick couplings
Rubber & thermoplastic hose
Tube fittings & adapters
Tubing & plastic fittings



Hydraulics

Key Markets

Aerial lift
Agriculture
Alternative energy
Construction machinery
Forestry
Industrial machinery
Machine tools
Marine
Material handling
Mining
Oil & gas
Power generation
Refuse vehicles
Renewable energy
Truck hydraulics
Turf equipment

Key Products

Accumulators
Cartridge valves
Electrohydraulic actuators
Human machine interfaces
Hybrid drives
Hydraulic cylinders
Hydraulic motors & pumps
Hydraulic systems
Hydraulic valves & controls
Hydrostatic steering
Integrated hydraulic circuits
Power take-offs
Power units
Rotary actuators
Sensors



Instrumentation

Key Markets

Alternative fuels
Biopharmaceuticals
Chemical & refining
Food & beverage
Marine & shipbuilding
Medical & dental
Microelectronics
Nuclear Power
Offshore oil exploration
Oil & gas
Pharmaceuticals
Power generation
Pulp & paper
Steel
Water/wastewater

Key Products

Analytical Instruments
Analytical sample conditioning products & systems
Chemical injection fittings & valves
Fluoropolymer chemical delivery fittings, valves & pumps
High purity gas delivery fittings, valves, regulators & digital flow controllers
Industrial mass flow meters/controllers
Permanent no-weld tube fittings
Precision industrial regulators & flow controllers
Process control double block & bleeds
Process control fittings, valves, regulators & manifold valves



Seal

Key Markets

Aerospace
Chemical processing
Consumer
Fluid power
General industrial
Information technology
Life sciences
Microelectronics
Military
Oil & gas
Power generation
Renewable energy
Telecommunications
Transportation

Key Products

Dynamic seals
Elastomeric o-rings
Electro-medical instrument design & assembly
EMI shielding
Extruded & precision-cut, fabricated elastomeric seals
High temperature metal seals
Homogeneous & inserted elastomeric shapes
Medical device fabrication & assembly
Metal & plastic retained composite seals
Shielded optical windows
Silicone tubing & extrusions
Thermal management
Vibration dampening



ENGINEERING YOUR SUCCESS.

Parker Fluid Connectors Group

North American Divisions & Distribution Service Centers

Your complete source for quality tube fittings, hose & hose fittings, brass & composite fittings, quick-disconnect couplings, valves and assembly tools, locally available from a worldwide network of authorized distributors.

Fittings:

Available in inch and metric sizes covering SAE, BSP, DIN, GAZ, JIS and ISO thread configurations, manufactured from steel, stainless steel, brass, aluminum, nylon and thermoplastic.

Hose, Tubing and Bundles:

Available in a wide variety of sizes and materials including rubber, wire-reinforced, thermoplastic, hybrid and custom compounds.

Worldwide Availability:

Parker operates Fluid Connectors manufacturing locations and sales offices throughout North America, South America, Europe and Asia-Pacific.

For information, call toll free...

1-800-C-PARKER
(1-800-272-7537)

North American Divisions

Fluid System Connectors Division

Otsego, MI
phone 269 692 6555
fax 269 694 4614

Engineering Support:
fscapps@parker.com

Customer Support:
fscsales@parker.com

Quote Support:
fscquote@parker.com

Hose Products Division

Wickliffe, OH
phone 440 943 5700
fax 440 943 3129

Parflex Division

Ravenna, OH
phone 330 296 2871
fax 330 296 8433

Quick Coupling Division

Minneapolis, MN
phone 763 544 7781
fax 763 544 3418

Tube Fittings Division

Columbus, OH
phone 614 279 7070
fax 614 279 7685

Distribution Service Centers

Buena Park, CA

phone 714 522 8840
fax 714 994 1183

Conyers, GA

phone 770 929 0330
fax 770 929 0230

Louisville, KY

phone 502 937 1322
fax 502 937 4180

Portland, OR

phone 503 283 1020
fax 503 283 2201

Toledo, OH

phone 419 878 7000
fax 419 878 7001
fax 419 878 7420
(FCG Kit Operations)

Canada

Milton, ONT

phone 905 693 3000
fax 905 876 1958

Mexico

Toluca, MEX

phone (52) 722 2754 200
fax (52) 722 2722 168

Parker Hannifin Corporation
Fluid System Connectors Division

300 Parker Drive
Otsego, MI 49078
Phone: 480 830 7764
Fax: 480 325 3571

transaircustomerservice@parker.com
www.parker.com/transair

