

INSTALLATION INSTRUCTIONS

Low Rise Car Lift

TL07

Capacity 7000 lbs.
(Maximum 1750 lbs. per pad)

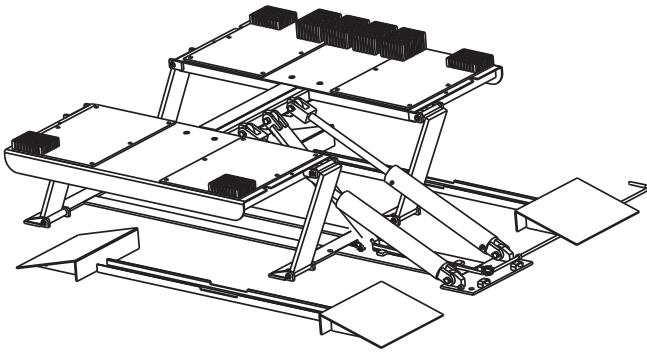

TL10

Capacity 10,000 lbs.
(Maximum 2500 lbs. per pad)

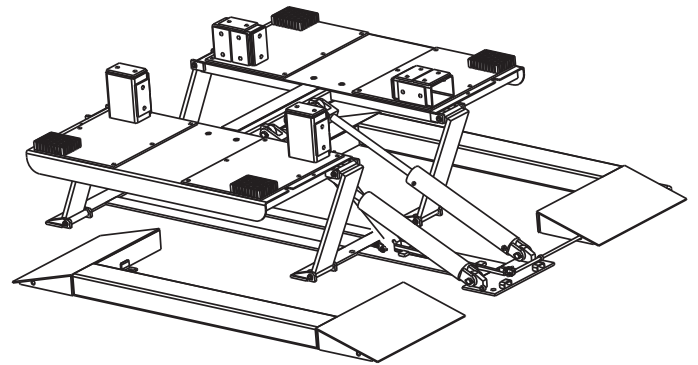

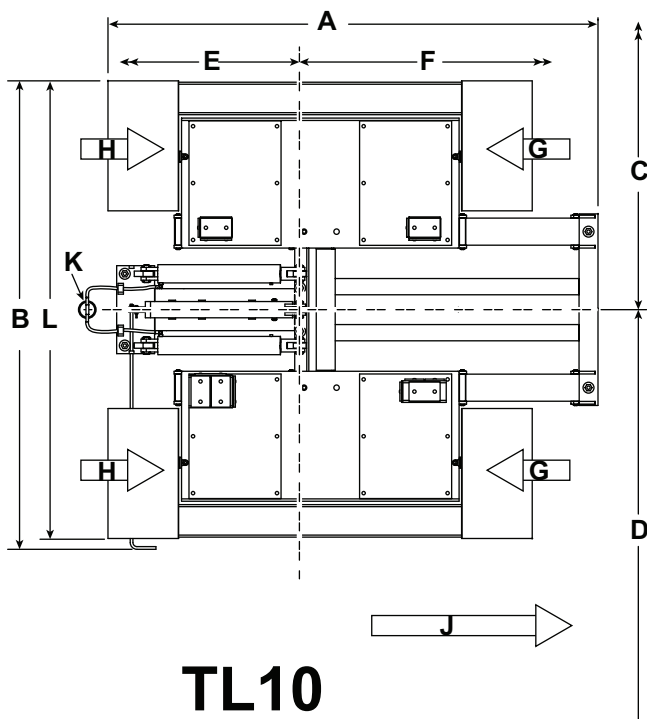

TL10

CLEARANCE AROUND TL10 LIFT

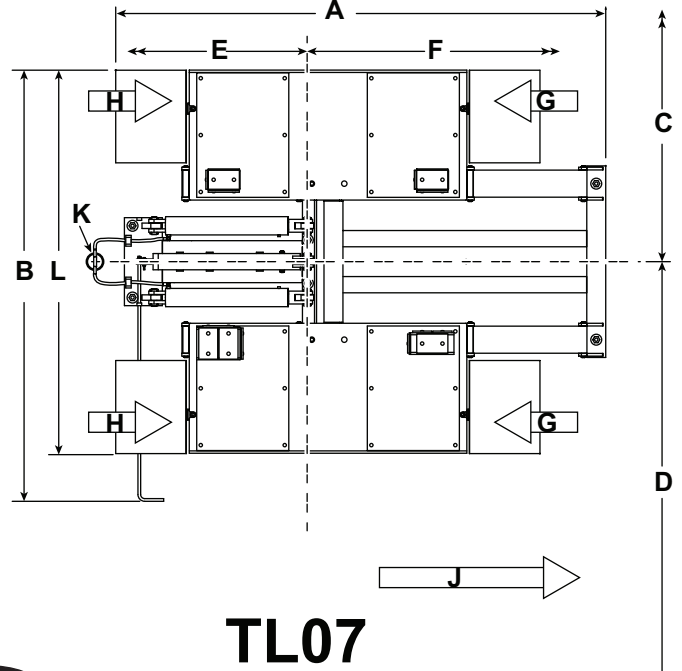

TL07

CLEARANCE AROUND TL07 LIFT

Fig. 1

- A. Overall Length 7'-7" (2311mm)
- B. Overall Width 7'-3" (2210mm)
- C. Minimum To Center Of Next Lift 11'-0" (3353mm)
- D. Minimum To Nearest Obstruction 5'-0" (1981mm)
- E. Minimum For 24' (7315mm) Bay
 - Standard Approach (G) 10'-9" (3277mm)
 - Optional Approach (H) 13'-3" (4039mm)
- F. Minimum For 24' (7315mm) Bay
 - Standard Approach (G) 13'-3" (4039mm)
 - Optional Approach (H) 10'-9" (3277mm)
- G. Approach
- H. Approach (Optional)
- J. At Full Rise Lift Moves 15" In This Direction
- K. 2" Conduit to Power Unit (Optional).
- L. Width of Platform/Base 7'-1/2" (2146mm)

- A. Overall Length 7'-7" (2311mm)
- B. Overall Width 6'-8" (2032mm)
- C. Minimum To Center Of Next Lift 11'-0" (3353mm)
- D. Minimum To Nearest Obstruction 5'-0" (1981mm)
- E. Minimum For 24' (7315mm) Bay
 - Standard Approach (G) 10'-9" (3277mm)
 - Optional Approach (H) 13'-3" (4039mm)
- F. Minimum For 24' (7315mm) Bay
 - Standard Approach (G) 13'-3" (4039mm)
 - Optional Approach (H) 10'-9" (3277mm)
- G. Approach
- H. Approach (Optional)
- J. At Full Rise Lift Moves 15" In This Direction
- K. 2" Conduit to Power Unit (Optional).
- L. Width of Platform/Base 5'-11" (1803mm)

NOTE:

Lift can be installed with cylinder end pointing towards front or rear of bay. **Be alert to differences in lift clearance requirements according to installation option chosen and customer preference.**

1. Lift Location: Always check architect's building plans when applicable. The lift should be located on a relatively level floor in a space which will allow adequate working space around the vehicle, Fig. 1.

Note: Lift can be installed with cylinder end pointing towards front (typical) or rear of bay. **Be alert to differences in lift clearance requirements according to installation option chosen and customer preference.**

DO NOT install on asphalt or other similar unstable surfaces.

Note: At full rise, the lift moves the vehicle 15" (381mm), Fig. 2.

2. Remove shipping bands and wood skids from lift.

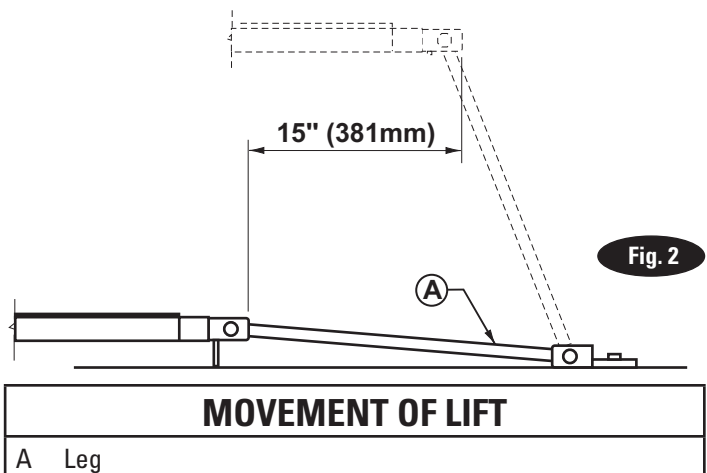

Fig. 2

MOVEMENT OF LIFT

A Leg

3. Anchoring:

- A. The anchor bolts must be installed at least 4-3/4" (121mm) from any edge or seam in the concrete
- B. Concrete shall have a compression strength of at least 3,000 PSI (20N/mm²) and a minimum thickness of 4-1/4" (108mm) in order to achieve a minimum anchor embedment of 3-1/4" (83mm). When using the standard supplied 3/4" x 5-1/2" lg. anchors, if the top of the anchor exceeds 2-1/4" above the floor grade, you DO NOT have enough embedment.
- C. Drill (8) 3/4" dia. holes in concrete floor using holes in base plate as a guide, see Fig. 3 & 4.

Note: DO NOT install anchors in holes marked "B" until AFTER lift is raised, see Fig. 4.

CAUTION DO NOT install on asphalt or other similar unstable surfaces.

- D. Tighten the anchor bolts to 110 ft-lbs (150 N-m). Do not use an impact wrench on anchor bolts.
If after tightening the anchor supplied with the lift extends more than 2-1/4" (57mm) above the floor the anchor does not have enough embedment.

ANCHORING LIFT

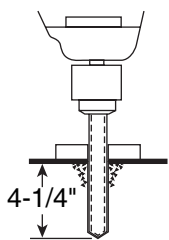

Drill hole using 3/4" carbide tipped masonry drill bit per ANSI standard B94.12.1977.

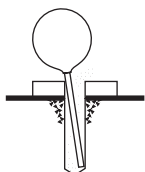

Clean Hole.

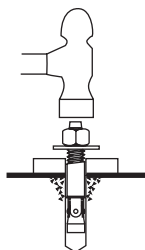

Run nut down just below impact section of bolt. Drive anchor into hole until nut & washer contact base.

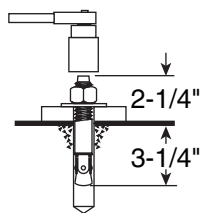

Tighten nut with Torque Wrench to 110 ft-lbs (150 N-m)

Fig. 3

SEISMIC - Varies by location consult with your structural engineer and manufacturer's representative.

IMPORTANT If an anchor will not reach the appropriate torque level or does not have enough embedment or adequate spacing cannot be achieved, replace the concrete under the lift with a 7' wide x 9' deep x 6" thick pad (2m x 2.7m x 152mm) of 3,000 psi (20N/mm²) concrete keyed under the existing floor. Let the concrete cure before reinstalling the lift.

IMPORTANT The frame must not be twisted, bent or otherwise misaligned by unlevel floors or improper anchoring. Misalignment will cause damage to the lift. Maximum out-of-level at anchors is: 1/4" (6mm) side to side; 1/2" (13mm) front to rear. If floor is crowned more than 1/4" (6mm) between front to rear anchors, shim at anchors. Top structure to be parallel to bases within 1/4" (6mm). Use shim kit FJ2426, or use grout to level the floor.

ANCHOR LOCATIONS

A	Holes not used
B	Drill (2) holes for 3/4" anchors through top, install after raising.
C	Drill (6) holes and install 3/4" anchors.

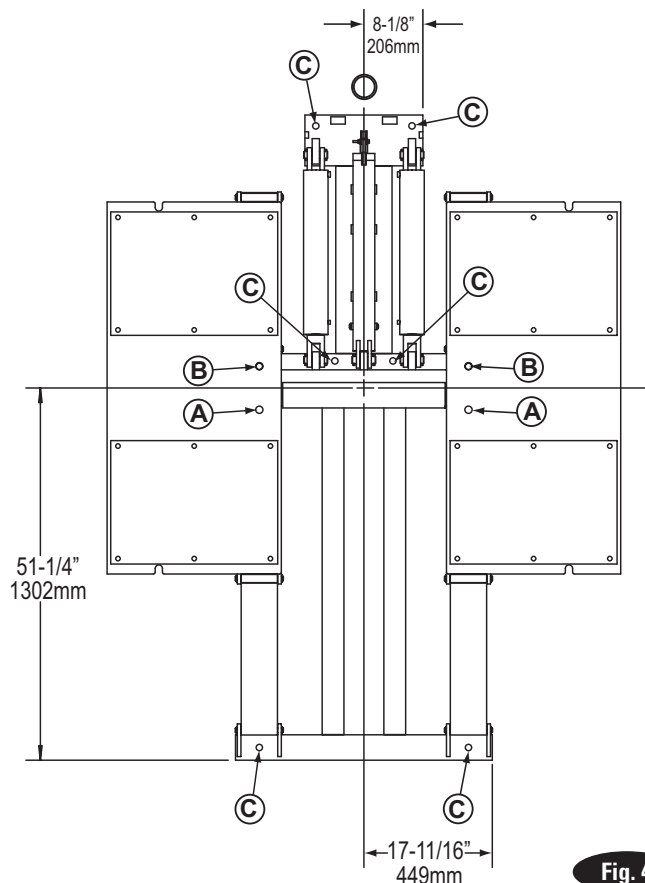

Fig. 4

***The supplied concrete fasteners meet the criteria of the American National Standard "Automotive Lifts - Safety Requirements for Construction, Testing, and Validation" ANSI/ALI ALCTV-2011, and the lift owner is responsible for all charges related to any additional anchoring requirements as specified by local codes. Contact customer service for further information at: 800.423.1722**

4. Install Power Unit And Mounting Post:

- A. Refer to architect’s plan for placement of power unit mounting post. Using the stand as a template mark location of (4) floor anchor holes. Note, the post uses a 1/2” diameter anchor which is different from the lift. Using a 1/2” carbide drill bit, drill and install anchors for the post.
- B. Attach four 5/16” x 1-1/4” bolts to the highest two and lowest two holes in the mounting bracket with 5/16” plain nuts. Attach the power unit, to these bolts and secure with 5/16” nylon insert nuts.
- C. Add fluid. Remove the fill-cap from the tank and fill with Dexron III ATF or hydraulic oil that meets ISO 32, until fluid reaches the MIN _____ mark on the power unit. Replace the fill-cap.

5. Electrical:

- A. The power unit comes completely wired and ready to plug into a 115 volt, single phase, 60 Hz. Circuit. A six foot, 3-wire power cord with grounding plug is provided. See Motor Operating Data Table, Fig. 5.

IMPORTANT Use separate circuit with time delay fuse or circuit breaker for each power unit. For single phase 115V use 25 amp. fuse. Wiring and power unit locations must comply with local electrical codes.

- B. Optional 208V-230V operated: Have a certified electrician run 230V single phase 60Hz power supply to 2 HP motor, Fig. 5. Size wire for 20 amp circuit. See Motor Operating Data table.

Single Phase Power Unit

Motor Operating Data - Single Phase	
Line Voltage	Running Motor Voltage Range
208-230 Volts 60 HZ	197-253 Volts

Motor Operating Data - Single Phase	
Line Voltage	Running Motor Voltage Range
115 Volts 60 HZ	103-127 Volts

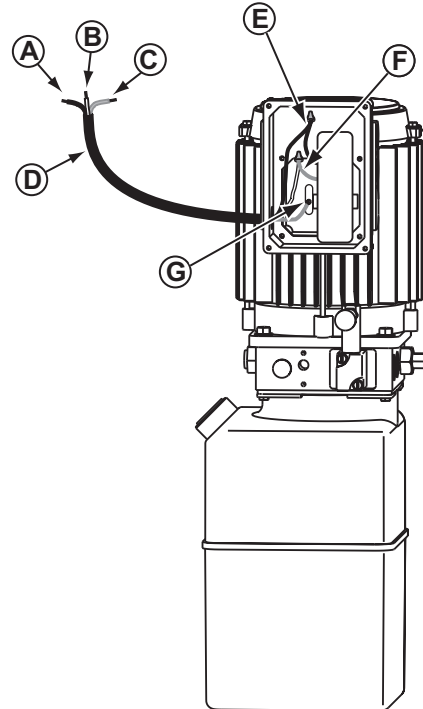

Power Unit Wiring Detail	
A	Black Wire
B	White Wire
C	Green Wire
D	208-230V 60HZ Single Phase
E	Attach Black Wire to Black Wire.
F	Attach White Wire to Red Wire
G	Attach Ground Wire here.

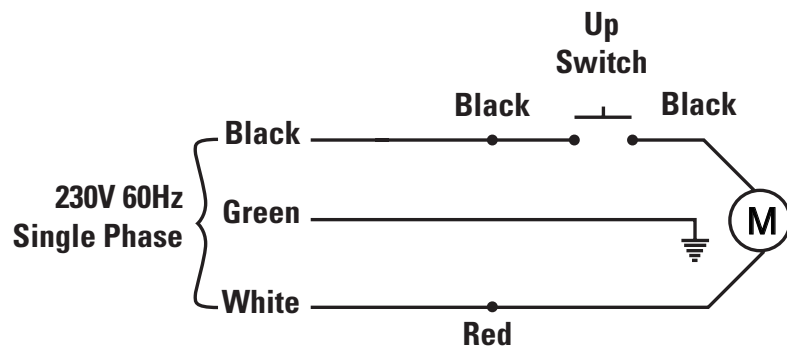
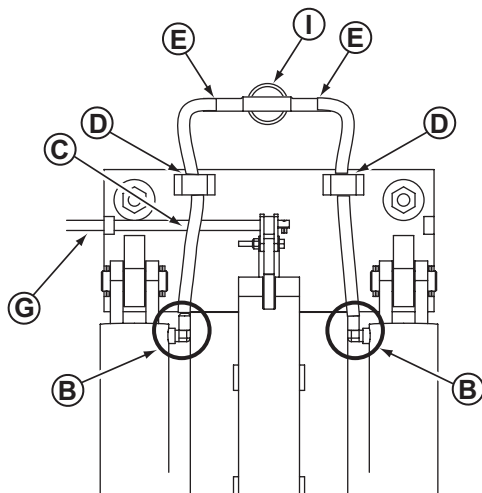
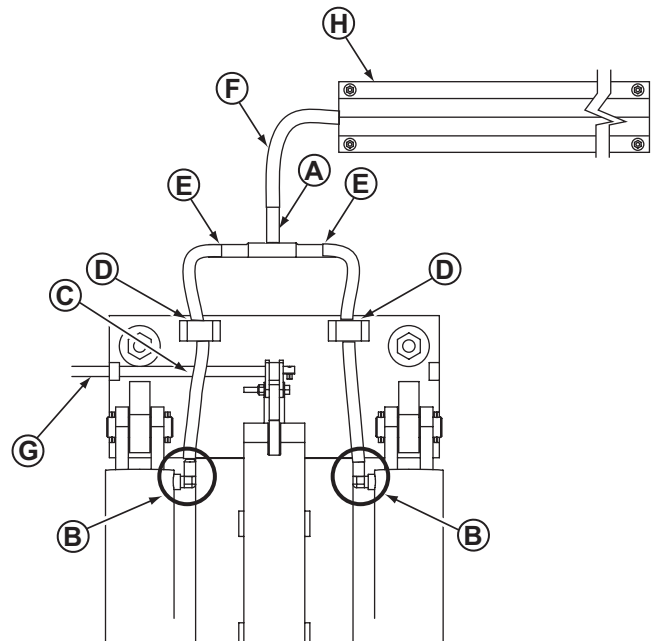

Fig. 5



Hose Routing (with Conduit)



Hose Routing (with Hose Guard)

Fig. 6

6. Running Hoses And Bleeding The Hydraulic System:

A. **⚠️WARNING** When attaching hydraulic fittings with pipe threads to the cylinders use Teflon tape. DO NOT start the Teflon tape closer than 1/8" (3mm) from the end of the fitting. Failure to comply may cause damage to the hydraulic system.

B. **⚠️WARNING** When tightening connections with flared (JIC) fittings, always follow the following tightening instructions. Failure to follow these instructions may result in cracked fittings and / or leaks. Use the proper size wrench. The nut portion of the fitting is the only part that should turn during tightening. The flare seat MUST NOT turn. Screw the fittings together hand tight. Using a 11/16" wrench to rotate the nut portion of the fitting 2-1/2 hex flats.

Back the fitting off one full turn. Again, tighten the fitting hand tight, then rotate the nut portion of the fitting 2-1/2 hex flats.

- C. Connect the long hydraulic hose to the branch on the JIC tee fitting, Fig 6 (F).
- D. Connect a male pipe thread to male JIC elbow to the port near the base end of each cylinder. The fittings should face toward the front of the lift (towards conduit or hose guard) and up 5 to 10 degrees, the cylinders will rotate upward as the lift rises, Fig. 6 (B).
- E. Connect the short hydraulic hoses to the elbows on the cylinders, Fig. 6 (B). These connections should be hand-tight only. Feed the free ends of the hoses thru the hose guides, Fig. 6 (C & D).
- F. Connect short hoses to the runs on the JIC tee fitting, Fig. 6 (E).

A	JIC tee fitting
B	JIC elbows
C	Short hydraulic hose to be routed over latch release handle as shown.
D	Feed the free ends of the short hydraulic hoses thru the hose guides as shown.
E	Short hoses to be connected to the runs on the JIC tee fitting.
F	Long hydraulic hose to be either routed through 2" conduit or through the hose guard as shown. This is according to the installation option chosen by customer.
G	Latch release handle
H	Hose guard (Note: Hose guards are not to be used if conduit is in concrete, DO NOT anchor at this time.)
I	2" conduit to power unit

- G. With the lift at it's lowest position loosen the connections between the hoses and fittings attached to the cylinders. Do not loosen the connections between the fittings and the cylinders themselves.
- H. Run the power unit until fluid appears at the cylinder ports. Tighten the hose connections.
- I. Add fluid to the system as previously described.

7. Positioning The Ramps:

- The ramps should be positioned as shown in Fig. 7, with a minimum of 1/2" (3mm), Dimension (A), clearance between the ramp and the front edge of the pad opposite the cylinders and 5/8" (16mm), Dimension (B), clearance between the outside surfaces of the pad and the inside surface of the ramps. **DO NOT DRILL ANCHOR HOLES AT THIS TIME!**
- Raise and lower the lift through one cycle and ensure there is adequate clearance between the ramps and the pad.

8. Installing The Lock Release Handle:

- Insert the latch release handle through the access hole in the ramp nearest the power unit.
 - Insert the keyed end of the handle through the keyway in the latch release weldment as shown in Fig. 8.
 - Install the roll pin into the end of the handle as shown in Fig. 8.
- Note:** Lift is shipped with two (2) latch release handles. Installer must choose one (1) based on customer requirement.

9. Anchoring The Ramps:

Note the ramps use a 1/2" diameter anchor which is different from the lift. Using a 1/2" carbide drill bit, drill holes and install (4) anchors to the ramps.

RAMP CLEARANCE TABLE	
A	1/2" (13mm) minimum clearance.
B	5/8" (16mm) minimum clearance.
C	Anchor hole locations for wheel dish.

10. Installing Hose Guard:

Note: Hose guards ARE NOT to be used if conduit is in concrete.

- Position hose guard over hose. Note: Hose guard is to be used to prevent damage of hose when driven over and to prevent tripping.
- Drill (4) 1/4" anchor holes and install anchors.

11. Final Adjustments:

- Install and tighten the remaining two anchors as described in Fig. 4.
- If any problems are encountered, do not proceed with subsequent steps. Instead, resolve the problem before proceeding by referencing the Troubleshooting portion of the Owner's Manual section of this manual.
- Raise the lift empty to the top of its travel and lower it the floor three (3) times to remove the remaining air from the hydraulic system and to verify that the power unit won't stall at relief pressure.
- Position a vehicle on the lift, raise to full height and lower onto the safety latches. Lower the vehicle to the floor.
- After cycling the lift ten times with a vehicle on it, recheck the tightness of the lift anchors to 65 ft-lbs (88 N-m).

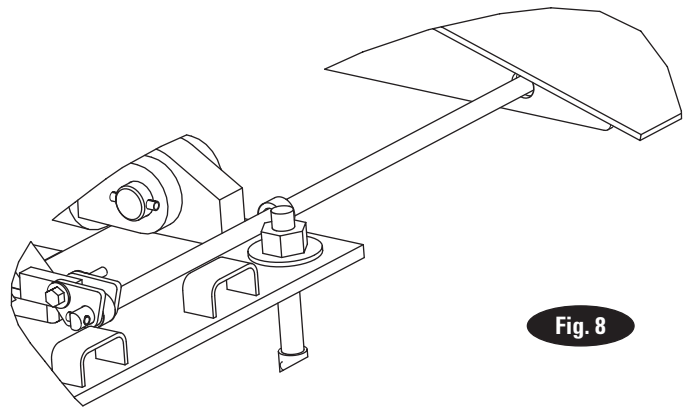
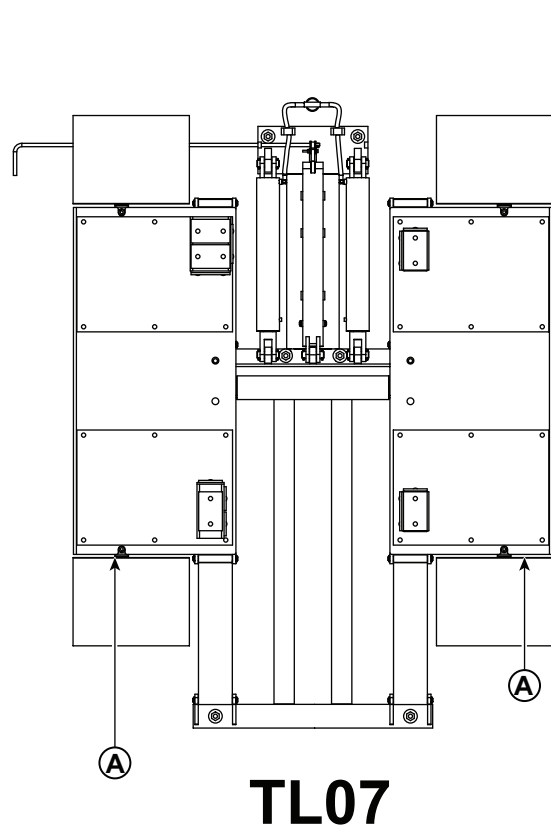
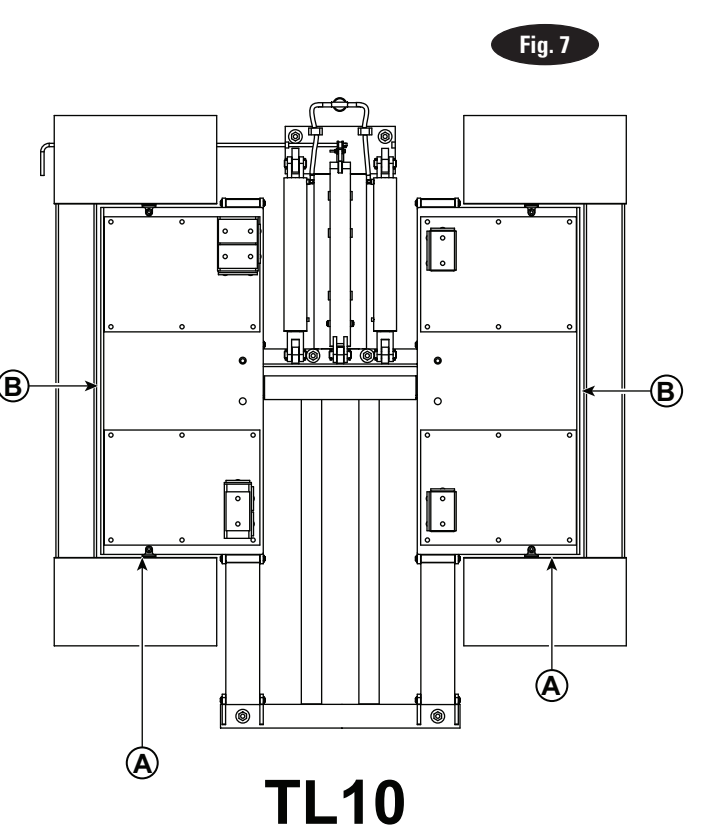

Fig. 8



PARTS BREAKDOWN

Low Rise Car Lift

TL07

Capacity 7000 lbs.
(Maximum 1750 lbs. per pad)

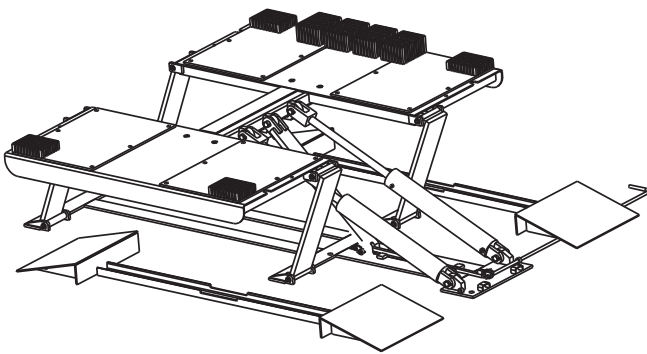

TL10

Capacity 10,000 lbs.
(Maximum 2500 lbs. per pad)

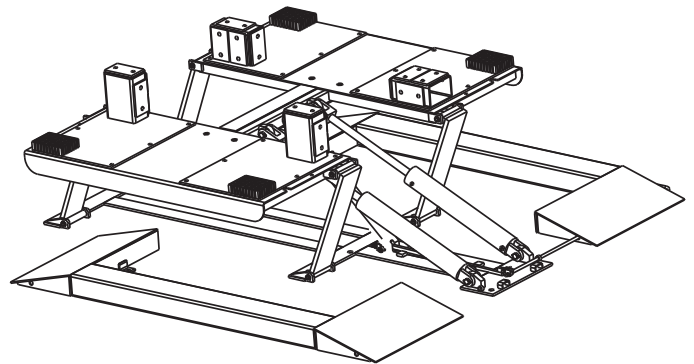

1.	CYLINDER PIN	021420
2.	7' POWER UNIT MOUNT	021704
3.	1/4"-20 NYLON INSERT HEX NUT	911403
4.	1/4" FLAT WASHER	911405
5.	1/4"-20 HHCS X 2" LG.	911481
6.	5/16"-18 HEX NUT	911701
7.	5/16"-18 NYLON INSERT HEX NUT	911703
8.	5/16"-18 HHCS X 1-1/4 LG.	911751
9.	1/2" X 4-1/4" ANCHOR BOLT	912728
10.	3/4" X 5-1/2" ANCHOR BOLT	913828
11.	SPRING PIN	0970609
12.	ROLL PIN X 1-1/2"	991060
13.	HOSE GUARD ANCHOR	991345
14.	CYLINDER	992305
15.	REAR LEG	1010100
16.	FRONT LEG	1010101
17.	BASE	1010106
18.	LEG PIN	1010116
19.	1/2" KLIP-RING	1010117
20.	5/8" KLIP-RING	1010118
21.	RUBBER PAD	1010400
22.	TOP STRUCTURE	1010401
23.	LOCKING LEG	1010500

24.	LATCH PIN	1010505
25.	LATCH RELEASE HANDLE	1010509
	LATCH RELEASE 4-1/2" HANDLE	FC633
26.	LATCH RELEASE KEYED PIVOT	1010510
27.	LATCH RELEASE PIVOT	1010511
28.	LATCH RELEASE	1010527
29.	LATCH PIN	1010514
30.	RAMP	
	TL10 (Shown)	1010600
	TL07 (Not Shown)	1010605
31.	3" RUBBER ADAPTER (TL07 Only)	FJ2428
32.	CHRISTMAS TREE FASTENER	1010906
33.	ADAPTER ASSEMBLY (TL10 Only)	1010907
34.	RUBBER PAD (VLXS10 Only)	1010908
35.	HYDRAULIC KIT	1010909
	17" HYDRAULIC HOSE	992217
	3/8" MJIC TEE	992502
	3/8" MJIC x 3/8" MNPT 90° ELBOW	992402
	9/16" O-RING x 3/8" MJIC 90° ELBOW	FJ7224
	117-1/2" HYDRAULIC HOSE*	992131
36.	180" HYDRAULIC HOSE	992517
	115V 60Hz POWER UNIT	P3083
	208-230V 60Hz POWER UNIT	P3084
	3Ø/208-230V/480V POWER UNIT	P3567
	1Ø/220V 50Hz POWER UNIT	P3503
37.	1-1/2" RUBBER ADAPTER	FJ2427
38.	HOSE GUARD	021730
39.	DRUM SWITCH ASSEMBLY (FOR 3Ø)	FA7366
40.	M5 x 10 PHMS PLATED (FOR 3Ø)	40275
*Hose used prior to Jan. 2008		

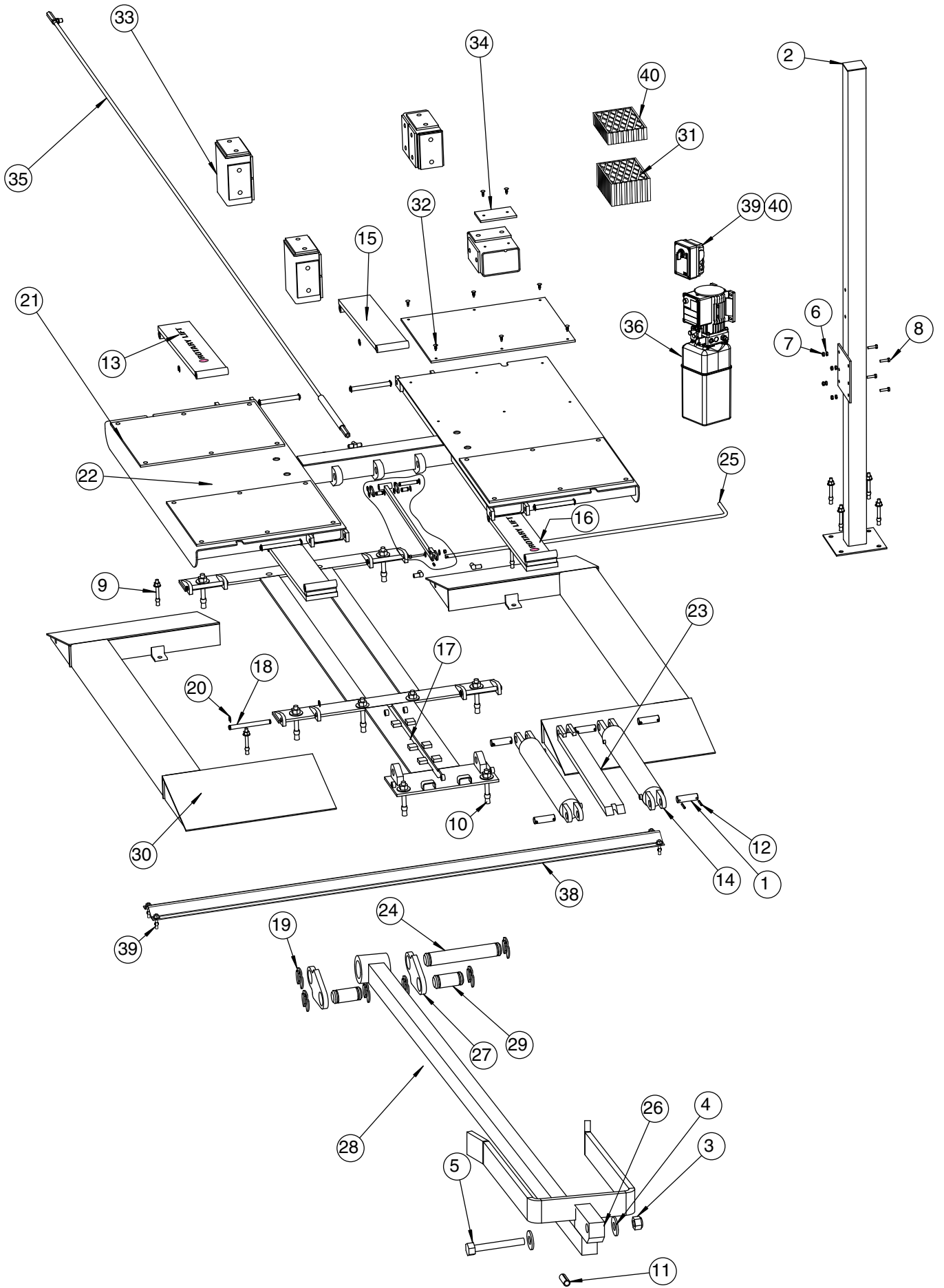

OPERATION MANUAL

Low Rise Car Lift

TL07

Capacity 7000 lbs.
(Maximum 1750 lbs. per pad)

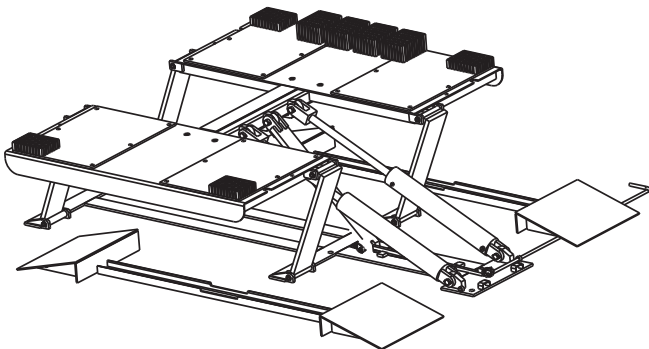

TL10

Capacity 10,000 lbs.
(Maximum 2500 lbs. per pad)

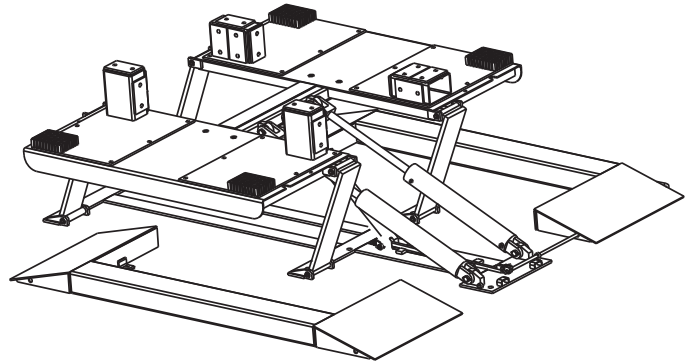

SAFETY INSTRUCTIONS

- **Daily** inspect your lift. Never operate if it malfunctions or if it has broken or damaged parts. Use **only** qualified lift service personnel and genuine Rotary parts to make repairs.
- **Thoroughly** train all employees in use and care of lift, using manufacturer's instructions and "Lifting It Right" and "Safety Tips" supplied with the lift.
- **Never** allow unauthorized or untrained persons to position vehicle or operate lift.
- **Prohibit** unauthorized persons from being in shop area while lift is in use.
- **Do Not** permit anyone on lift or inside vehicle when it is either being raised or lowered.
- **Always** keep area around lift free of tools, debris, grease and oil.
- **Never** overload lift. Capacity of TL10 lift is 10,000 lbs., 2500 lbs. per pad. Capacity of TL07 lift is 7000 lbs., 1750 lbs. per pad.
- **Do Not** stand in front of the lift or vehicle while it is being positioned in lift bay.
- Before driving vehicle into lift bay, BE SURE lift is fully lowered.
- **Load** vehicle on lift carefully. Position lift adapters to contact at the vehicle manufacturer's recommended lift points. Raise lift until adapters contact vehicle. Check adapters for secure contact with vehicle. Raise lift to desired working height.

CAUTION Do Not go under vehicle if locking latches are not engaged.

- **Do Not** block open or override self-closing lift controls; they are designed to return to the "Off" or Neutral position when released.
- **Remain clear** of lift when raising or lowering vehicle.
- **Always** lower lift completely and disconnect power source before disconnecting hydraulic lines.
- **Avoid** excessive rocking of vehicle while on lift.
- **Clear** area if vehicle is in danger of falling.
- **Completely** lower lift before removing vehicle from lift area.
- **Release** locking latches before attempting to lower lift.

IMPORTANT The locking leg latch will reset automatically **ONLY** when the lift is fully lowered. If during the lowering process the lift is stopped before it gets to the fully lowered position, the locking leg **MUST** be reset by manually rotating the latch release handle.

The Owner/Employer:

- Shall ensure that lift operators are qualified and that they are trained in the safe use and operation of the lift using the manufacturer's operating instructions; ALI/SM 93-1, *ALI Lifting it Right* safety manual; ALI/ST-90 *ALI Safety Tips* card; ANSI/ALI ALOIM-2000, *American National Standard for Automotive Lifts-Safety Requirements for Operation, Inspection and Maintenance*; ALI/WL Series, *ALI Uniform Warning Label Decals/Placards*; and in the case of frame engaging lifts, ALI/LP-GUIDE, *Vehicle Lifting Points/Quick Reference Guide for Frame Engaging Lifts*.
- Shall establish procedures to periodically inspect the lift in accordance with the lift manufacturer's instructions or ANSI/ALI ALOIM-2000, *American National Standard for Automotive Lifts-Safety Requirements for Operation, Inspection and Maintenance*; and The Employer Shall ensure that lift inspectors are qualified and that they are adequately trained in the inspection of the lift.
- Shall establish procedures to periodically maintain the lift in accordance with the lift manufacturer's instructions or ANSI/ALI ALOIM-2000, *American National Standard for Automotive Lifts-Safety Requirements for Operation, Inspection and Maintenance*; and The Employer Shall ensure that lift maintenance personnel are qualified and that they are adequately trained in the maintenance of the lift.
- Shall maintain the periodic inspection and maintenance records recommended by the manufacturer or ANSI/ALI ALOIM-2000, *American National Standard for Automotive Lifts-Safety Requirements for Operation, Inspection and Maintenance*.
- Shall display the lift manufacturer's operating instructions; ALI/SM 93-1, *ALI Lifting it Right* safety manual; ALI/ST-90 *ALI Safety Tips* card; ANSI/ALI ALOIM-2000, *American National Standard for Automotive Lifts-Safety Requirements for Operation, Inspection and Maintenance*; and in the case of frame engaging lifts, ALI/LP-GUIDE, *Vehicle Lifting Points/Quick Reference Guide for Frame Engaging Lifts*; in a conspicuous location in the lift area convenient to the operator.
- Shall provide necessary lockout/tagout means for energy sources per ANSI Z244.1-1982 (R1993), *Safety Requirements for the Lockout/Tagout of Energy Sources*, before beginning any lift repairs.
- Shall not modify the lift in any manner without the prior written consent of the manufacturer.

3. **Loading:** **IMPORTANT** Vehicle manufacturer's recommended pick up points **MUST** be able to be engaged by lift structure or adapter blocks. Vehicle frame **MUST** be strong enough to support it's weight and has not been weakened by modification or corrosion. **DO NOT** raise limousines, specialty, or other modified vehicles.

Before lifting vehicle be sure that:

- A. Pads are in secure contact with frame or support structure at vehicle manufacturer's recommended pick up points.
- B. Certain vehicles such as Camaro, Firebird, Escort, or Chrysler "K" Cars or others may require additional clearance under carriage or exhaust system from contacting pad support. Use auxillary adapters. Locate at vehicle manufacturer's recommended pick up points.

Note: Allow (2) seconds between motor starts. Failure to comply may cause motor burnout.

4. To Raise Lift:

- A. Push Raise Switch (A) on power unit, Fig. 2.
- B. Stop before making contact with vehicle. Be sure wheels and/or mud flaps clear pad end ramps.
- C. Raise vehicle until tires clear the floor.
- D. Stop and check pads for secure contact at vehicle manufacturer's recommended lift points.
- E. Continue to raise to desired height only if vehicle is secure on lift.
- F. Repeat complete spotting, loading and raising procedures if required.
- H. Actuate Lowering Handle (B), Fig. 2, to lower lift onto locking latches.

CAUTION DO NOT go under vehicle if locking latches are not engaged.

5. While Using Lift:

- A. Avoid excessive rocking of vehicle while on lift.

6. To Lower Lift:

- A. Remove all tools, bystanders, and other objects from lift area.
- B. Raise lift off locking latches.
- C. Rotate Latch Release Handle, Fig. 3.
- D. Push Lowering Valve Handle (B) to lower lift, Fig. 2.

Note: The Lowering Valve Handles are deadman-type design. Each must be held down to lower lift.

CAUTION DO NOT override self-closing lift controls.

7. Remain clear of lift when lowering vehicle.

8. Remove adapters from under vehicle. Be sure lift is fully lowered before removing vehicle.

9. If lift is not operating properly, **Do Not** use until adjustment or repairs are made by qualified lift service personnel.

*Maximum operation pressure is:
2320 psi for TL07, TL10

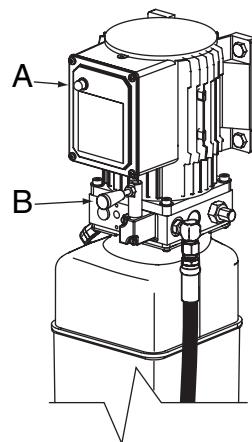

A. Raise Switch
B. Lowering Valve Handle

Fig. 2

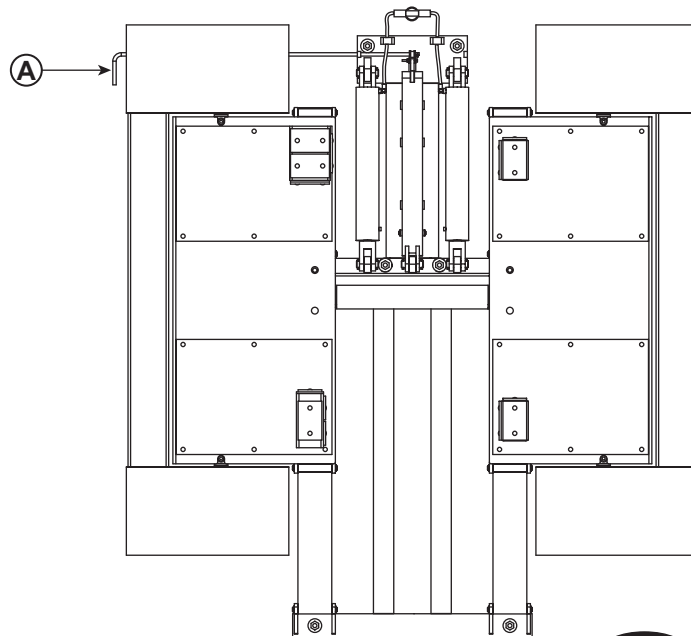

A. Latch Release Handle

Fig. 3

MAINTENANCE INSTRUCTIONS

⚠ WARNING If you are not completely familiar with automotive lift maintenance procedures **STOP**: Contact factory for instructions.

To Avoid Personal Injury, permit only qualified lift service personnel to perform maintenance on this equipment.





Use only genuine Rotary replacement parts for repairs.

- **Always** keep all bolts tight. Check periodically.
- **Always** raise lift when cleaning floor area.
- **Always** keep lift clean.
- **Daily**: Inspect adapters for damage or excessive wear. Replace as required.
- **Daily**: Check latch release handle on lift for damage or binding.
- **Weekly**: Inspect all lift parts for signs of damage due to overloading and rough handling.
- **Monthly**: Lubricate cylinder/locking leg bolt and locking leg release handle pivot.
- **Monthly**: Lubricate hinge joints if excessive rusting occurs.
- **Semi-Annually**: Check fluid level of lift power unit. With lift fully lowered, fluid should be at MIN ___ mark on tank. Refill if required per lift installation instructions. If fluid is required, inspect all hoses and seals. Repair as required.
- **Every 3 Months**: Check anchor bolts for tightness. Anchors should be torqued to 90 ft. lbs. (122 N-m).
- **If lift stops** short of full rise or chatters, check fluid level and bleed both cylinders per lift installation instructions.
- **Replace** all CAUTION, WARNING, or SAFETY related decals on the lift if unable to read or missing. Reorder labels from Rotary Lift.

SAFETY WARNING LABELS FOR HINGED FRAME ENGAGING LIFTS

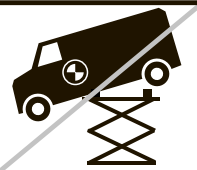
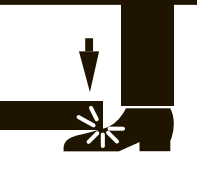
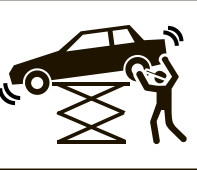
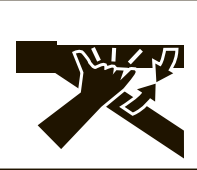
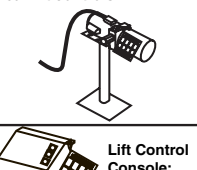
Lift Owner/User Responsibilities:

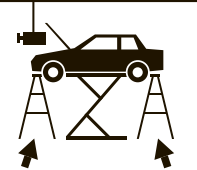
- A. This Safety Warning placard **SHALL** be displayed in a conspicuous location in the lift area.
- B. Use one of the mounting arrangements illustrated on back of this placard.
- C. These Safety Warning labels supplement other documents supplied with the lift.
- D. Be certain all lift operators read and understand these labels, operating instructions and other safety related information supplied with the lift.

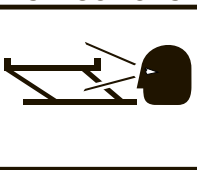
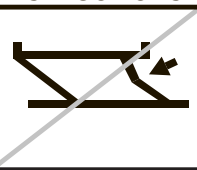
<p>⚠ WARNING</p>  <p>Position vehicle with center of gravity midway between adapters. ©</p>	<p>⚠ WARNING</p>  <p>Remain clear of lift when raising or lowering vehicle. ©</p>	<p>⚠ WARNING</p>  <p>Keep feet clear of lift while lowering. ©</p>
<p>⚠ WARNING</p>  <p>Clear area if vehicle is in danger of falling. ©</p>	<p>⚠ WARNING</p>  <p>Avoid excessive rocking of vehicle while on lift. ©</p>	<p>⚠ WARNING</p>  <p>Keep clear of pinch points when lift is moving. ©</p>
<p>⚠ CAUTION</p>  <p>Lift to be used by trained operator only. ©</p>	<p>Power Unit: Secure placard near lift controls.</p>  <p>Lift Control Console: Secure placard in an accessible location.</p> <p>The messages and pictographs shown are generic in nature and are meant to generally represent hazards common to all automotive lifts regardless of specific style.</p> <p>Funding for the development and validation of these labels was provided by the Automotive Lift Institute, PO Box 1519 New York, NY, 10101-1519.</p> <p>They are protected by copyright. Set of labels may be obtained from ALI or its member companies.</p> <p>© 1992 by ALI, Inc. ALI/WL300csw</p>	
<p>⚠ CAUTION</p>  <p>Authorized personnel only in lift area. ©</p>	<p>⚠ CAUTION</p>  <p>Use vehicle manufacturer's lift points. ©</p>	<p>⚠ CAUTION</p>  <p>Always use safety stands when removing or installing heavy components. ©</p>
<p>SAFETY INSTRUCTIONS</p>  <p>Read operating and safety manuals before using lift. ©</p>	<p>SAFETY INSTRUCTIONS</p>  <p>Proper maintenance and inspection is necessary for safe operation. ©</p>	<p>SAFETY INSTRUCTIONS</p>  <p>Do not operate a damaged lift. ©</p>

TROUBLE SHOOTING

Trouble	Cause	Remedy
Electric motor does not run.	<ol style="list-style-type: none"> 1. Check fuse or circuit breaker. 2. Check for correct voltage to motor. 3. Inspect all wiring connections. 4. Microswitch burned out. 5. Motor windings burned out. 	<ol style="list-style-type: none"> 1. Replace blown fuse or reset circuit breaker. 2. Supply correct voltage to motor. 3. Repair and insulate all connections. 4. Replace microswitch. 5. Replace motor.
Electric motor runs but will not raise lift.	<ol style="list-style-type: none"> 1. Motor runs in reverse rotation. 2. Open lowering valve. 3. Pump sucking air. 4. Suction stub off pump. 5. Low fluid level. 	<ol style="list-style-type: none"> 1. Change motor rotation by reversing motor leads. 2. Repair or replace lowering valve. 3. Tighten all suction line fittings. 4. Replace suction stub. 5. Fill tank with Dexron III ATF or ISO 32 hydraulic fluid.
Electric motor runs—raises unloaded lift but will not raise vehicle.	<ol style="list-style-type: none"> 1. Motor running on low voltage. 2. Trash in lowering valve. 3. Overloading lift. 4. Improper relief valve adjustment. 	<ol style="list-style-type: none"> 1. Supply correct voltage to motor. 2. Clean lowering valve. 3. Check vehicle weight and/or balance vehicle weight on lifts. 4. Replace relief valve cartridge.
Lift slowly settles down.	<ol style="list-style-type: none"> 1. Trash in check valve seat. 2. Trash in lowering valve seat. 3. External fluid leaks. 	<ol style="list-style-type: none"> 1. Clean check valve. 2. Clean lowering valve. 3. Repair external leaks.
Slow lifting speed or fluid blowing out fill/breather cap.	<ol style="list-style-type: none"> 1. Air mixed with fluid. 2. Air mixed with fluid suction. 3. Fluid return tube loose. 	<ol style="list-style-type: none"> 1. Change fluid to Dexron III ATF or ISO 32 hydraulic fluid. 2. Tighten all suction line fittings. 3. Reinstall fluid return tube.
Lift going up unlevel.	<ol style="list-style-type: none"> 1. Lift installed on unlevel floor. 	<ol style="list-style-type: none"> 1. Shim lift to level base, refer to page 2, step 3 in Installation Instruction.
Anchors will not stay tight.	<ol style="list-style-type: none"> 1. Concrete floor thickness or holding strength not sufficient. 	<ol style="list-style-type: none"> 1. Break out old concrete and repour new pad for lift.
Lift will not raise off of latches.	<ol style="list-style-type: none"> 1. Motor, pump, or cylinder failure. 	<ol style="list-style-type: none"> 1. Contact lift manufacturer's Customer Service.

LIFT LOCKOUT/TAGOUT PROCEDURE

Purpose

This procedure establishes the minimum requirements for the lockout of energy that could cause injury to personnel by the operation of lifts in need of repair or being serviced. All employees shall comply with this procedure.

Responsibility

The responsibility for assuring that this procedure is followed is binding upon all employees and service personnel from outside service companies (i.e., authorized installers, contactors, etc.). All employees shall be instructed in the safety significance of the lockout procedure by the facility owner/manager. Each new or transferred employee along with visiting outside service personnel shall be instructed by the owner/manager (or assigned designee) in the purpose and use of the lockout procedure.

Preparation

Employees authorized to perform lockout shall ensure that the appropriate energy isolating device (i.e., circuit breaker, fuse, disconnect, etc.) is identified for the lift being locked out. Other such devices for other equipment may be located in close proximity of the appropriate energy isolating device. If the identity of the device is in question, see the shop supervisor for resolution. Assure that proper authorization is received prior to performing the lockout procedure.

Sequence of Lockout Procedure

- 1) Notify all affected employees that a lockout is being performed and the reason for it.
- 2) Unload the subject lift. Shut it down and assure the disconnect switch is "OFF" if one is provided on the lift.
- 3) The authorized lockout person operates the main energy isolation device removing power to the subject lift.
 - If this is a lockable device, the authorized lockout person places the assigned padlock on the device to prevent its unintentional reactivation. An appropriate tag is applied stating the person's name, at least 3" x 6" in size, an easily noticeable color, and states not to operate device or remove tag.
 - If this device is a non-lockable circuit breaker or fuse, replace with a "dummy" device and tag it appropriately as mentioned above.
- 4) Attempt to operate lift to assure the lockout is working. Be sure to return any switches to the "OFF" position.
- 5) The equipment is now locked out and ready for the required maintenance or service.

Restoring Equipment to Service

- 1) Assure the work on the lift is complete and the area is clear of tools, vehicles, and personnel.
- 2) At this point, the authorized person can remove the lock (or dummy circuit breaker or fuse) & tag and activate the energy isolating device so that the lift may again be placed into operation.

Rules for Using Lockout Procedure

Use the Lockout Procedure whenever the lift is being repaired or serviced, waiting for repair when current operation could cause possible injury to personnel, or for any other situation when unintentional operation could injure personnel. No attempt shall be made to operate the lift when the energy isolating device is locked out.

OPERATING CONDITIONS

Lift is not intended for outdoor use and has an operating ambient temperature range of 41°-104°F (5°-40°C).

Vehicle Service GroupSM
2700 Lanier Drive
Madison, IN 47250, USA
1-800-640-5438
www.vsgdover.com



© **Vehicle Service GroupSM**
All Rights Reserved. Unless otherwise
indicated, **Vehicle Service GroupSM**
and all other trademarks are property
of Dover Corporation and its affiliates.