



2212 Camplain Rd., Hillsborough, NJ 08844

Call for Sales, Service, & Installation

www.fclift.com 908.526.1500



CL Challenger Lifts

15000

SITE SPECIFICATIONS

- **BAY HEIGHT:** 14'8" minimum
- **BAY WIDTH:** 14' recommended
- **BAY DEPTH:** 28' recommended
- **POWER REQ.:** 208-230v
Single Phase*, 30-amp breaker
- **MIN. CONCRETE SPEC:** 4" thick, reinforced, free from cracks/seams, rated at 3500+ psi, cured at least 28 days
- **AIR REQUIRED:** 90-120 psi

SERVICE BAY LAYOUT

FRONT OF COLUMN

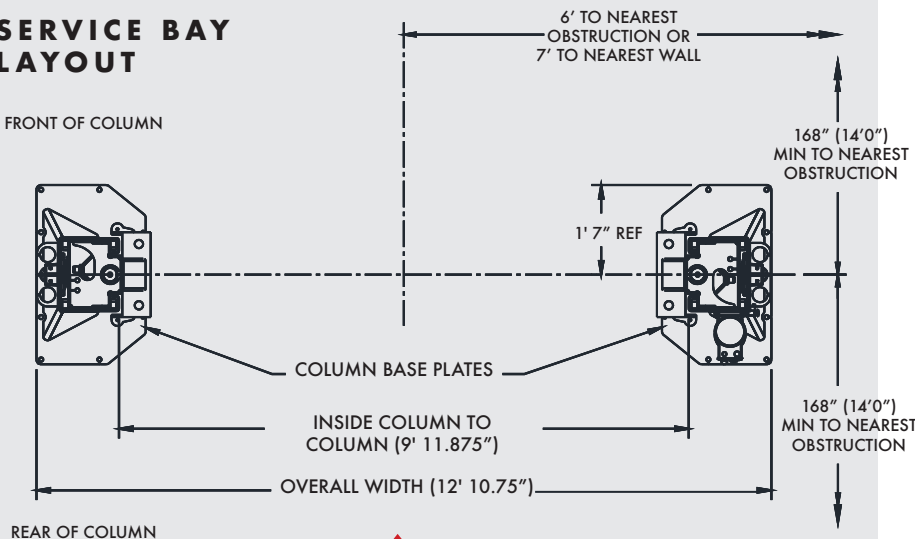

Model Number	15000-3S	15000
Lifting Capacity	15,000 lbs.	
Lifting Configuration	Symmetric	
Arms	HD 2-stage front/HD 2-stage rear	
Rise Height	82"	85"
Overall Height	174"	
Overall Width	154.75"	
Drive-Thru Clearance	104.25"	
Floor to Overhead Switch	167"	
Arm Reach (Min.)	36.625"	38.5"
Arm Reach (Max.)	75"	62"
Screw Pad Height	5.5" - 10.875"	6.625" - 8.5"
Inside Columns	119.875"	
Air Supply Required	90-120 psi	
Motor / Voltage	2HP, 208v-230v, 60Hz, 1Ph	
Speed of Rise	77 s	
Ceiling Height Required	14' 8"	
ALI/ETL Certified	√	√
2' Height Extension Available	√	√
Colors Available		

*3-phase upgrade is available for purchase

www.challengerlifts.com
1-800-648-5438