



2212 Camplain Rd., Hillsborough, NJ 08844

Call for Sales, Service, & Installation

www.fclift.com 908.526.1500



### SERVICE BAY LAYOUT

FRONT OF COLUMN

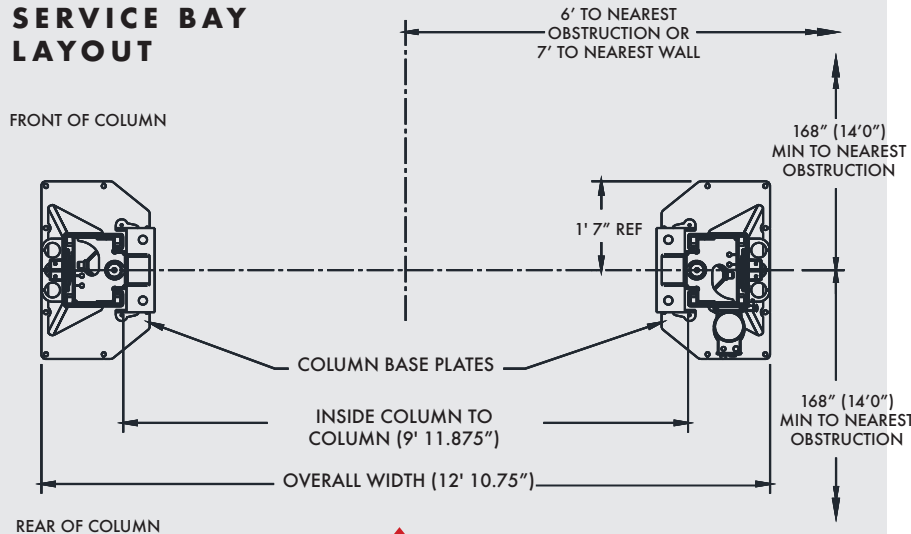

DRIVE ON DIRECTION



# 18000

## SITE SPECIFICATIONS

- **BAY HEIGHT:** 14'8" minimum
- **BAY WIDTH:** 14' recommended
- **BAY DEPTH:** 28' recommended
- **POWER REQ.:** 208-230v  
Single Phase\*, 30-amp breaker
- **MIN. CONCRETE SPEC:** 4" thick, reinforced, free from cracks/seams, rated at 3500+ psi, cured at least 28 days
- **AIR REQUIRED:** 90-120 psi

Model Number	18000
Lifting Capacity	18,000 lbs.
Lifting Configuration	Symmetric
Arms	HD 2-stage front/HD 2-stage rear
Rise Height	85"
Overall Height	174"
Overall Width	154.75"
Drive-Thru Clearance	104.25"
Floor to Overhead Switch	167"
Arm Reach (Min.)	38.5"
Arm Reach (Max.)	62"
Screw Pad Height	6.625" - 8.5"
Inside Columns	119.875"
Air Supply Required	90-120 psi
Motor / Voltage	2HP, 208v-230v, 60Hz, 1Ph
Speed of Rise	77 s
Ceiling Height Required	14' 8"
ALI/ETL Certified	√
2' Height Extension Available	√
Colors Available	

\*3-phase upgrade is available for purchase

www.challengerlifts.com  
1-800-648-5438