



2212 Camplain Rd., Hillsborough, NJ 08844

Call for Sales, Service, & Installation

www.fclift.com 908.526.1500



### SERVICE BAY LAYOUT

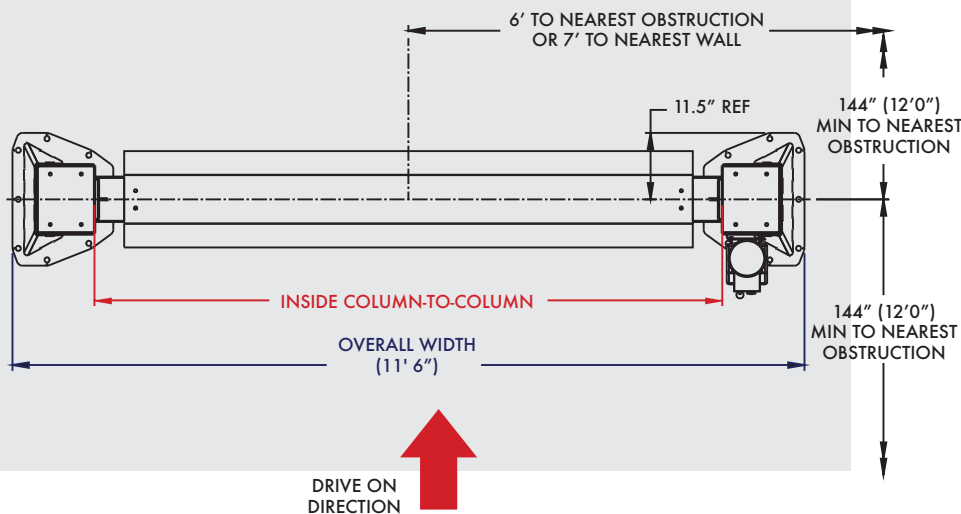

# CLFP9

## SITE SPECIFICATIONS

- **BAY HEIGHT:** 10' 2" minimum
- **BAY WIDTH:** 12' recommended
- **BAY DEPTH:** 24' recommended
- **POWER REQ.:** 208-230v Single Phase\*, 30-amp breaker
- **MIN. CONCRETE SPEC:** 4" thick, reinforced, free from cracks/seams, rated at 3500+ psi, cured at least 28 days

Model Number	CLFP9
Lifting Capacity	9,000 lbs.
Lifting Configuration	Symmetric
Arms	3-stage front/3-stage rear
Overall Height	120.875"
Rise Height	78.125"
Screw Pad Height	4" / 5.875"
Overall Width	137.5"
Inside Columns	109"
Drive-Thru Clearance	98.187"
Floor to Overhead Switch	-
Front Arm Reach	24.5" / 44.5"
Rear Arm Reach	24.5" / 44.5"
Motor / Voltage	2HP, 208v-230v, 60Hz, 1Ph
Speed of Rise	50 s
Ceiling Height Required	10' 2"
ALI/ETL Certified	-
2' Height Extension Available	-
3' Height Extension Available	-
Colors Available	

\*3-phase upgrade is available for purchase

www.challengerlifts.com  
1-800-648-5438