



2212 Camplain Rd., Hillsborough, NJ 08844

Call for Sales, Service, & Installation

www.fclift.com 908.526.1500

OFFSET 3-STAGE ARM



SERVICE BAY LAYOUT

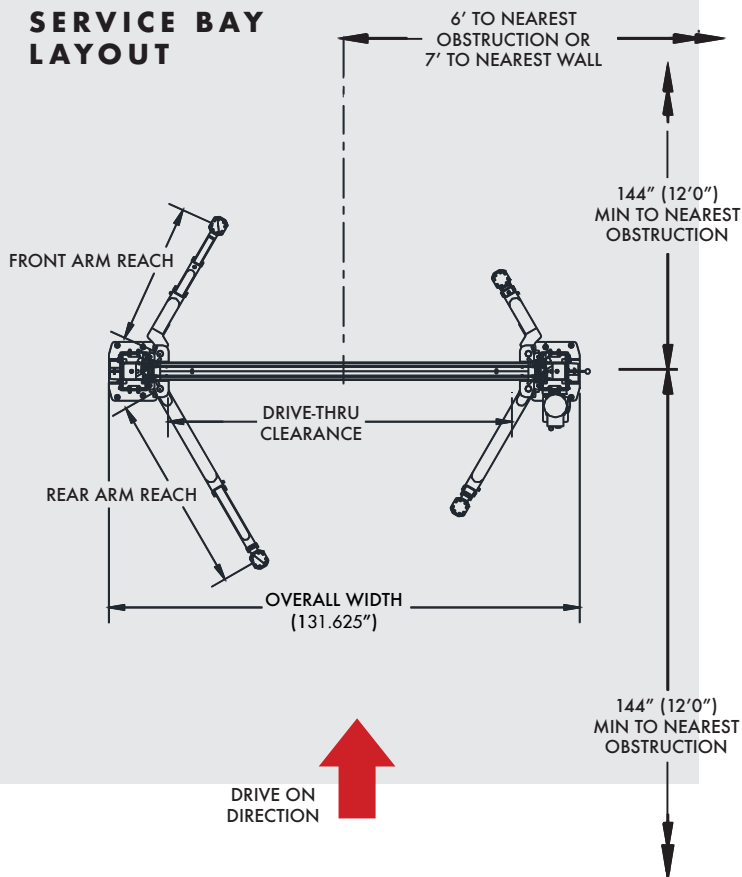

VLE10

SITE SPECIFICATIONS

- **BAY HEIGHT:** 12' minimum
- **BAY WIDTH:** 12' recommended
- **BAY DEPTH:** 24' recommended
- **POWER REQ.:** 208-230v Single Phase*, 30-amp breaker
- **MIN. CONCRETE SPEC:** 4" thick, reinforced, free from cracks/seams, rated at 3500+ psi, cured at least 28 days

Model Number	VLE10
Lifting Capacity	10,000 lbs.
Lifting Configuration	Symmetric & Asymmetric
Arms	3-stage front/2-stage rear
Overall Height	143.875"
Rise Height	74.75"
Screw Pad Height	4.25" / 6.75"
Overall Width	131.625"
Inside Columns	110.25"
Drive-Thru Clearance	98.375"
Floor to Overhead Switch	137"
Front Arm Reach	22.3" / 39.375"
Rear Arm Reach	38.75" / 55.375"
Motor / Voltage	2HP, 208v-230v, 60Hz, 1Ph
Rise Time	44 s
Ceiling Height Required	12'
ALI/ETL Certified	√
2' Height Extension Available	√
Colors Available	

*3-phase upgrade is available for purchase



www.challengerlifts.com
1-800-648-5438