



2212 Camplain Rd., Hillsborough, NJ 08844

Call for Sales, Service, & Installation

[www.fcilift.com](http://www.fcilift.com) **908.526.1500**



# WIDE INGROUND LIFTS

Challenger Lifts' EW0820 wide-configuration hydraulic cassette-style inground lift provides extra wide drive-through for wide-bodied and electric vehicles. It features 3-stage arms and double telescoping screw pads, and bench mounted controls.



**EW0820S090**  
8,000 LB. CAPACITY



» Wide-configuration inground lift

## **CL** Challenger Lifts

LOUISVILLE, KENTUCKY

## FEATURES & BENEFITS

- » ALI-certified
- » 8,000 lb. lifting capacity
- » Chrome non-breathing ram style cylinder provides for longer lift life
- » Enhanced wiper at top and bottom of bearing provides better grease retention and minimizes contaminants from entering into bearings
- » Mechanical lock engages every 4" allowing ergonomic working height for technicians to increase productivity and minimize fatigue
- » Fully contained and sealed galvanized steel cassette tub eliminates risk of hydraulic fluid seeping into the ground
- » Premium double telescoping screw pads adjust to multiple heights minimizing the need for adapters
- » Widely spaced structure allows for a large, unobstructed workspace, especially useful for battery access on new electric vehicles

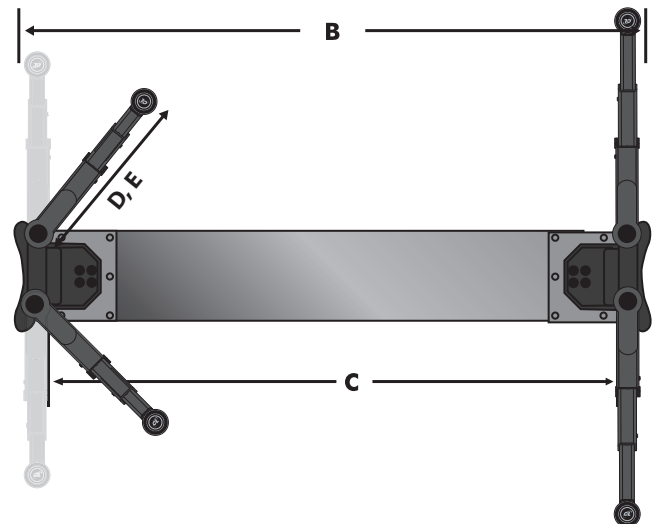
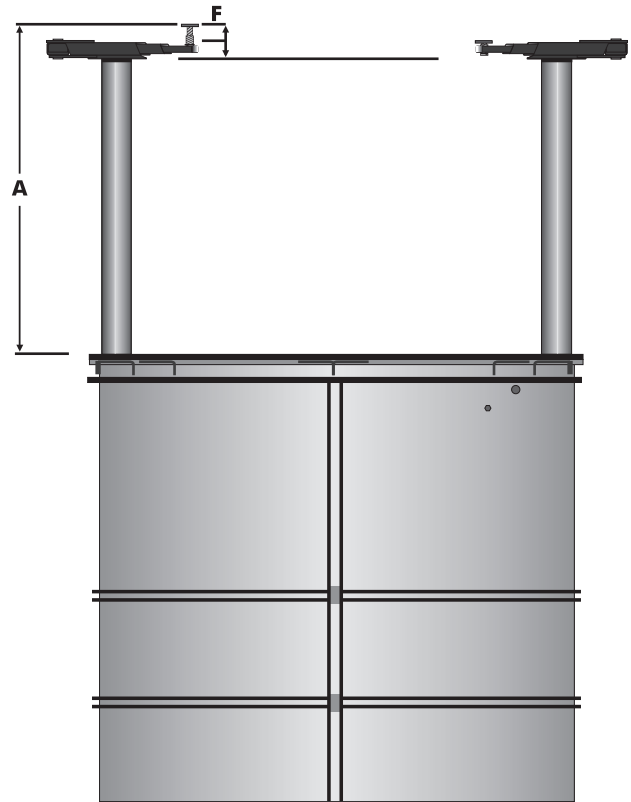

Model Number	EW0820
Lifting Capacity	8,000 lb.
<b>A</b> Rise Height	73.25"
<b>B</b> Width Overall	115.75"
<b>C</b> Drive-Thru Clearance	102"
<b>D</b> Arm Reach Min	25.25"
<b>E</b> Arm Reach Max	45.25"
<b>F</b> Min. Screw Pad Height	3.75"
Capacity (Per Arm)	2,000 lb.
Guide Plunger Diameter	5"
Motor	3HP
Voltage (Single Phase Std.)	208v - 230v
Speed of Rise	38 s
Air Required	75 - 125 psi

For more information, contact your Authorized Challenger Lifts Distributor:



2212 Camplain Rd., Hillsborough, NJ 08844

Call for Sales, Service, & Installation

[www.fcilift.com](http://www.fcilift.com) **908.526.1500**

800-648-5438 | 502-625-0700 | Fax: 502-625-0711 | Email: [sales@challengerlifts.com](mailto:sales@challengerlifts.com)  
2311 South Park Road | Louisville, KY 40219

