



2212 Camplain Rd., Hillsborough, NJ 08844

Call for Sales, Service, & Installation

www.fcilift.com **908.526.1500**

10,000 LB. LOW-RISE LIFT

SRM10 MODEL*



Challenger's low-rise 10,000 lb lift, model SRM10, is perfect for any brake or express tire service needs a shop has. Capable of lifting vehicles, ranging from small passenger cars to light trucks, while keeping a small floor footprint. Standard spotting blocks and optional auxiliary adapters reach a more comprehensive range of vehicle lift points.

NEW FEATURES

- Louvered approach ramps for better traction for vehicle approach and removal.
- Longer lasting pad.

FEATURES AND BENEFITS

- Small footprint when space is short.
- Excellent for express tire service.
- Flush Mount installation optional

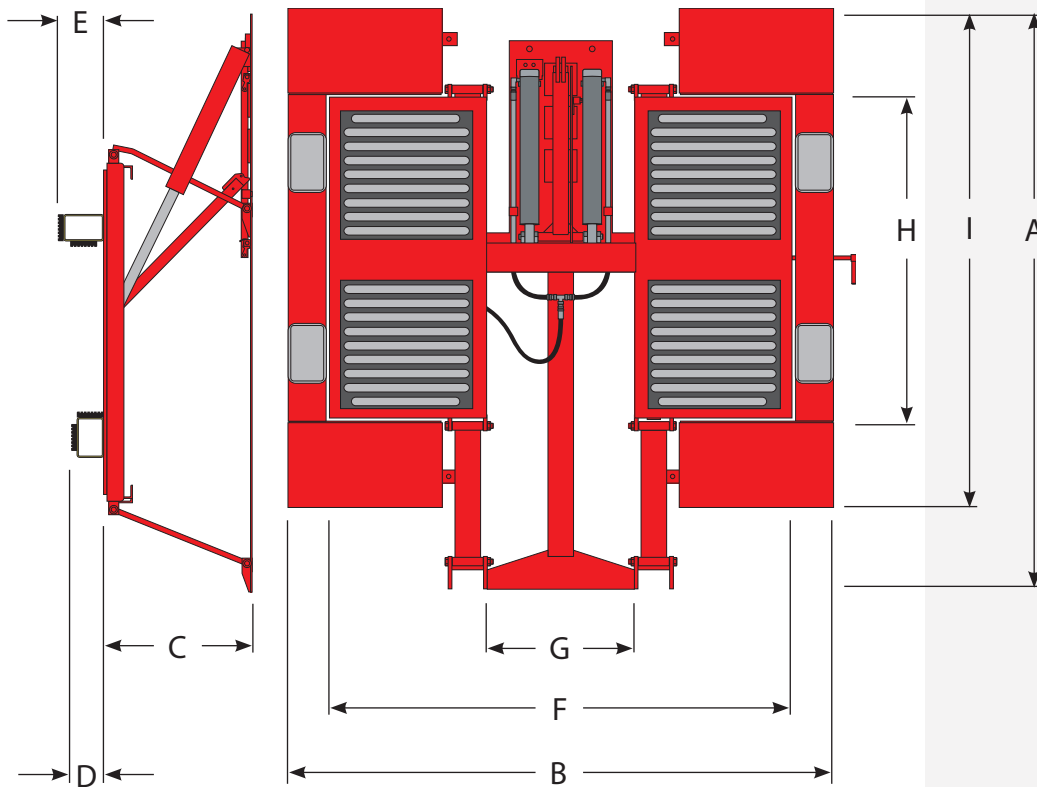

Model Number	SRM10
Lifting Capacity	10,000 lbs.
A Overall Length	92.875"
B Overall Width	85" (+2.5" for handle)
C Rise Height	22"
Lowered Height	4.25"
Locking Bar Heights	13.75", 18.25", 21.25"
D Low Adapter Position	4.75"
E High Adapter Position	6.75"
F Outside Width of Platforms	72"
G Width Between Platforms	23"
H Platform Overall Length	50"
I Ramp and Platform Overall Length	82.5"
Rearward Movement	13.25"
Std. Motor / Voltage	1HP, 115v, 60Hz, 1Ph
ALI/ETL Certified	✓
Available Colors	

Accessories

Part Number	Description
SR10-1	Two-position steel adapter blocks with rubber pads (set of 4)
10354	Surface mounted steel hose guard kit includes two 64" pieces and one 20" piece
10356	Surface mounted steel hose guard kit includes three 20" pieces
10549	1.5" Spotter block auxiliary adapter (set of 4)
10554	3" Spotter block auxiliary adapter (set of 4)
63100	4.125" Spotter block auxiliary adapter (set of 4)

