



2212 Camplain Rd., Hillsborough, NJ 08844

Call for Sales, Service, & Installation

www.fcilift.com 908.526.1500



SERVICE BAY LAYOUT

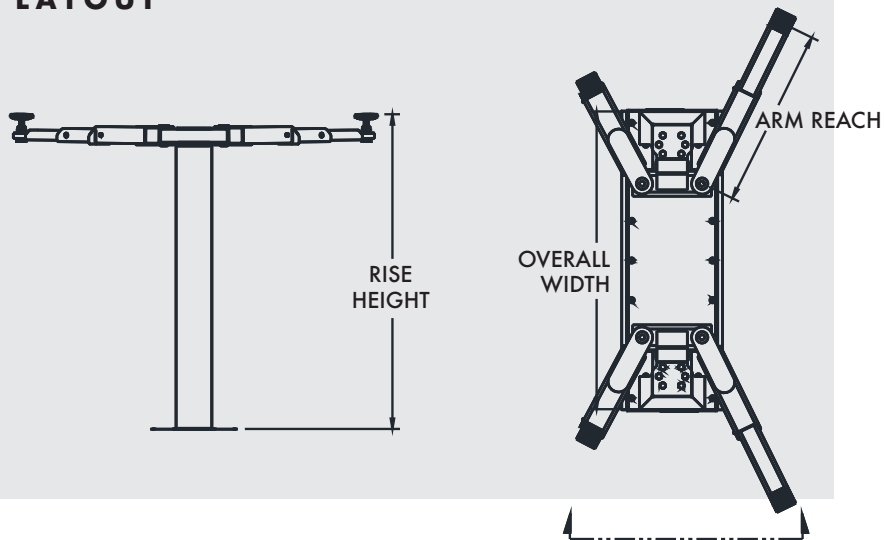

EV1520

SITE SPECIFICATIONS

- **BAY HEIGHT:** 12' minimum
- **BAY WIDTH:** 12' recommended
- **BAY DEPTH:** 24' recommended
- **POWER REQ.:** 208-230v Single Phase*, 30-amp breaker
- **AIR REQUIRED:** 90-120 psi

Model Number	EV1520
Lifting Capacity	15,000 lbs.
Arms	2-stage front/2-stage rear
Stroke	68"
Rise Height	84.25"
Width Overall	71.5"
Drive-Thru Clearance	-
Reach (Arm Minimum)	26.25"
Reach (Arm Maximum)	43"
Screw Pad Height	6.5" - 8.75"
Capacity	3,750 lbs. per arm
Guide Plunger Diam.	8.5"
Motor / Voltage	2HP, 208v-230v, 60Hz, 1Ph
Speed of Rise	49 s
Air Required	90 - 120 psi
ALI/ETL Certified	√
Super Structure Colors	

*3-phase upgrade is available for purchase

www.challengerlifts.com
1-800-648-5438