



2212 Camplain Rd., Hillsborough, NJ 08844

Call for Sales, Service, & Installation

www.fclift.com 908.526.1500



EV1220

SITE SPECIFICATIONS

- **BAY HEIGHT:** 12' minimum
- **BAY WIDTH:** 12' recommended
- **BAY DEPTH:** 24' recommended
- **POWER REQ.:** 208-230v Single Phase*, 30-amp breaker
- **AIR REQUIRED:** 90-120 psi

SERVICE BAY LAYOUT

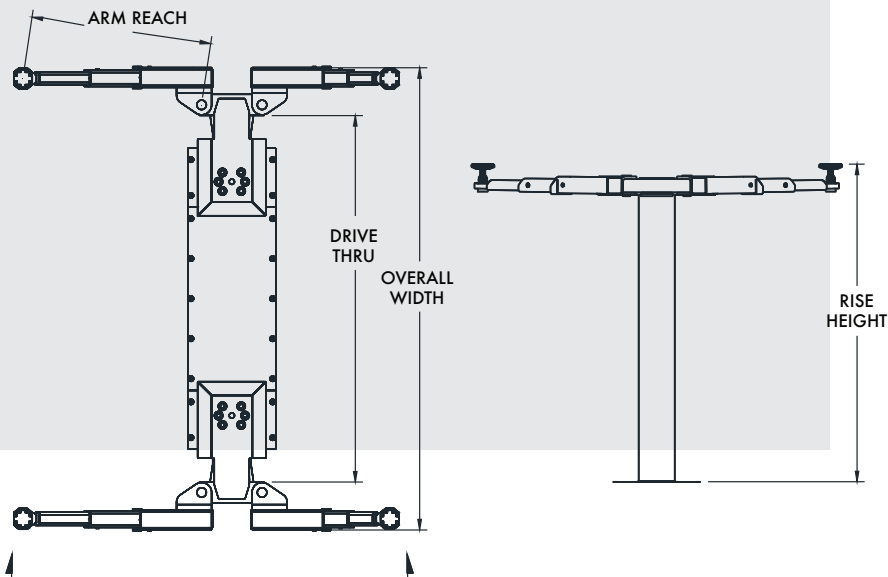

Model Number	EV1220	EV1220-QC
Lifting Capacity	12,000 lbs.	
Arms	3-stage front/3-stage rear	
Stroke	68"	
Rise Height ¹	80.75"	
Width Overall	115"	
Drive-Thru Clearance	87"	
Reach (Arm Minimum)	19.625"	
Reach (Arm Maximum)	48"	
Screw Pad Height	5" - 6.75"	
Capacity	3,000 lbs. per arm	
Guide Plunger Diam.	8.5"	
Motor / Voltage	2HP, 208v-230v, 60Hz, 1Ph	3HP, 208v-230v, 60Hz, 1Ph
Speed of Rise	60 s	38 s
Air Required	90 - 120 psi	
ALI/ETL Certified	√	
Super Structure Colors		

*3-phase upgrade is available for purchase

¹Rise height is measured with superstructure in highest position.

www.challengerlifts.com
1-800-648-5438